

IN-FAUNAL STUDY OF WETLAND RESTORATION  
IN  
THE HOLE-IN-THE-DONUT,  
EVERGLADES NATIONAL PARK  
1990 - 1992.

APRIL, 1994

GEORGE H. DALRYMPLE  
DEPARTMENT OF BIOLOGICAL SCIENCES  
FLORIDA INTERNATIONAL UNIVERSITY  
MIAMI, FLORIDA 33199

TABLE OF CONTENTS

	Page
List of Tables.....	iii
List of Figures.....	iv
Acknowledgments.....	vii
Introduction.....	1
Methods.....	5
Results and Discussion.....	14
Summary and Conclusions.....	26
Literature cited.....	30
Appendix 1: Habitats sampled.....	a
Appendix 2: Copy of paper by Dalrymple, 1988 .....	f

List of Tables.

1. Species list and sample sizes for fishes by habitats.
2. Species list and sample sizes for tadpoles by habitats.
3. Species list and trap data for herpetofaunal drift fence trapping.
4. Species list and sample sizes for strip transects for birds by habitats.
5. Species list and sample sizes for dragonfly larvae by habitats.
6. Species list for snails.

List of Figures.

Figure 1. Rarefaction curves for fish species richness by habitat.

Figure 2. Observed species richness in samples of fishes by habitat, and expected (from rarefaction curves) number of species in samples of 100 fishes.

Figure 3. Percent composition of habitat samples for fishes sampled (Codes from Table 1).

Figure 4. Cluster analysis of habitats using standardized data for fish samples by habitat (data and codes are from Table 1).

Figure 5. Cluster analysis of standardized data for fishes by taxa (data and codes are from Table 1).

Figure 6. Principal components analysis (PCA) of standardized fish data by habitats (data and codes are from Table 1).

Figure 7. Principal components analysis (PCA) of standardized fish data by taxa (data and codes from Table 1).

Figure 8A. Relative abundance (percent occurrence in samples) of tadpole species in habitats (codes from Table 2). Figure 8B. The duration of larval period for tadpoles (codes from Table 2).

Figure 9. Cluster analysis of tadpole data based on absence/presence in Table 2, codes from Table 2).

Figure 10. Cluster analysis of tadpole data from Figure 3 and Table 1

Figure 11. Principal components analysis (PCA) of tadpole data by habitats, based on absence/presence in Table 2, codes from Table 2; Cypress Dome, CD, data is identical loading on all three principal components as Marsh, MAR, data).

Figure 12. Cluster analysis of drift fence samples by habitat using standardized data based on Table 3 (codes for taxa and habitats in Table 3; data for Prairies and Brazilian pepper forest in HID (= DIST) are from Dalrymple, 1988).

Figure 13. Cluster analysis of drift fence samples by species using standardized data based on Table 3 (codes for taxa and habitats in Table 3; data for Prairies and Brazilian pepper forest in HID (= DIST) are from Dalrymple, 1988).

Figure 14. Principal components analysis (PCA) of drift fence samples by habitats using standardized data based on Table 3 (codes for taxa and habitats in Table 3; data for Prairies and Brazilian pepper forest in HID (= DIST) are from Dalrymple, 1988).

Figure 15. Principal components analysis (PCA) of drift fence samples by taxa using standardized data based on Table 3 (codes for taxa and habitats in Table 3; data for Prairies and Brazilian pepper forest in HID (= DIST) are from Dalrymple, 1988).

Figure 16. Percent composition of samples of dragonfly larvae from sampled habitats (codes are from Table 5).

Figure 17. Cluster analysis of standardized dragonfly larval data by habitats (code and data from Table 5).

Figure 18. Cluster analysis of standardized dragonfly data by taxa (codes and data from Table 5).

Figure 19. Principal components analysis (PCA) of standardized dragonfly larval data by habitats (codes for taxa and habitats from Table 5).

Figure 20. Principal components analysis (PCA) of standardized dragonfly larval data by taxa (codes for taxa and habitats from Table 5).

## ACKNOWLEDGEMENTS

This research was sponsored by Everglades National Park, supplementary agreement to Florida International University. The continued dedication and interest of Bob Doren in seeing the Hole-in-the-Donut restored made every aspect of this project easier. His patience in waiting for this final report, in the light of the difficulties faced in recovering, more than the data, after Hurricane Andrew are much appreciated. Keith Bradley helped collect data from bird transects, Nancy Dalrymple helped in collection and identification of tadpoles and bird transect analyses, Damian Lue and Luis Gonzalez helped with collections and fish identification, Tony Koop identified dragonfly larvae; and Javier Gonzalez, Brian Machovina, and Michael Nemeth helped set up drift fences.

## INTRODUCTION

Recent efforts to restore short hydroperiod sawgrass prairies in the Everglades region involved removal of rock-plowed artificial soils, and grading the limestone surface to, or below original surface elevation. Study of graded and ungraded wetland restoration attempts in the East Everglades revealed that the lower surface level resulted in longer hydroperiod and the colonization of the area by native wetland plants, while ungraded sites were colonized by exotic vegetation and fewer wetland plant species (Dalrymple, Dalrymple, and Fanning, 1993).

The same method, soil removal and grading, was combined with exotic plant (Brazilian pepper, Schinus terebinthefolis) removal, on secondary successional old agricultural fields of the Hole-in-the-Donut, HID, in Everglades National Park (Doren and Whitaker, 1988; Berger, 1993). The HID had become dominated by a monoculture of Brazilian pepper that had disrupted natural plant and animal community organization and function, increased productivity and altered food chains (Ewel, Ojima, Karl, and DeBusk, 1984; Krauss, 1987; Dalrymple, 1988; Doren and Whitaker, 1988; Curnutt, 1989). The initial restoration effort was applied to 40 hectares of HID. The site was divided into two experimental treatments: complete soil removal and grading (HIDA) on 24 ha, and partial soil removal only (HIDB) on 16 ha. The preliminary study of the plant community of the HID restoration areas indicate that a new secondary successional

process that is dominated with natural wetland plants has occurred on the area where complete soil removal and grading occurred, but that reinvasion of Brazilian pepper has been rapid, and the flora of the area is a mixture of wetland and upland species, dominated by weedy herbaceous and woody species (Doren and Whitaker, 1988).

Study of the animal invasions of the restoration treatments also needed to be done to determine whether such restoration attempts are leading to natural faunal recolonization of the sites. The objective of this research was an evaluation of restoration attempts in terms of faunal composition. In order to evaluate restoration attempts in the **HID**, I compared restored **HID** wetlands to natural wetlands with regard to animal species that are strongly tied to aquatic conditions. The evaluation emphasized faunal composition, and habitat use, with an emphasis on wetland in-fauna. In-fauna was defined as faunal elements with low cruising radius and low mobility. They are animals that spend either their whole lives in the wetlands setting, or use it for a critical element of their life histories (e.g. reproduction; cf. Harris, 1988). Species or life stages that are tied to seasonal flooding conditions included the aquatic larvae of frogs and toads (tadpoles), some amphibians and reptiles, and dragonfly larvae. Species that are tied to permanent aquatic conditions included fishes, some amphibians and reptiles, and snails.

It was the working hypothesis of this study that soil removal and surface grading in HIDA that are resulting in short hydroperiod wetlands, would also be re-colonized by a fauna that reflect natural sawgrass/muhly grass prairies of the surrounding region.

Since the restoration was designed to restore short hydroperiod prairies the sampling for this study was designed to be used in analyses that would compare in-fauna species composition between the restoration area and natural wetlands of the area including prairies, marshes, cypress domes and solution holes.

This study reveals that complete soil removal and grading, as seen in HIDA, which resulted in a longer hydroperiod, also resulted in an in-fauna that is most similar to short hydroperiod prairie. Partial soil removal did not increase hydroperiod long enough to permit the range of wetland in-fauna seen in either the complete soil removal area or natural prairies. The partial soil removal retained a higher load of exotic species, and like the surrounding Brazilian pepper forests, a peculiar combination of animals (especially birds).

The choice for this original restoration attempt was a compromise, wherein the convenience of easy road access was important for heavy equipment for tree and soil removal. Current limitations of faunal similarity between HIDA and natural wetlands, is a function of the isolation of the current restoration. Without direct contact with natural

wetlands, some animal species may be slow to, or never will colonize the restoration. Without direct contact with natural uplands (pinelands) the typical seasonal use of this restoration by many animal species will remain limited. The fact that the fauna contains more typical wetland species now is very encouraging for further restoration attempts in HID, but the isolation of the site and the fact that it is surrounded by Brazilian pepper forest results in a continual invasion of the area by exotic species that are most common in the disturbed agricultural area. Future efforts to restore wetlands in the HID would more rapidly reflect natural short hydroperiod prairies, if they were planned so that they are in direct contact with natural communities: restoration from the "outside - in", rather than from the "inside - out".

## METHODS:

### Habitats sampled.

Ten habitats were sampled and compared, at least three of each type of habitat were sampled twice a month, for a total of 30 sites and 60 collections per month. The wetland sites of most importance for comparisons were the restored sites and the natural equivalent that we were trying to restore: short hydroperiod prairies. Samples of these sites were of major importance. But given the high variability in environmental factors, especially rainfall, and the high variability in surface water with microtopography and microhabitat in the region, I included a wide range of wetland types in the overall analysis. Wetlands included were both macro- and micro- habitats as listed below (for more details see Appendix 1):

1. The **HID** restored site A: **HIDA**, complete soil removal.
2. The **HID** restored site B: **HIDB**, only partial soil removal.
3. The large pond in **HIDB**, **PONDB**, was treated as a separate habitat.
4. **HID** Brazilian Pepper dominated, non restored sites.
5. Marl, short-hydroperiod prairies.
6. Sawgrass, long-hydroperiod marshes.
7. Cypress Domes.
8. Willow Heads.
9. Pineland Solution Holes.
10. Hammock Solution Holes.

### Faunal Sampling.

Sampling began in April, 1991 and continued through August, 1992 (17 months).

Species richness, community composition, and relative abundance of selected species were compared between the **HID** restoration and natural wetlands. The faunal groups that were emphasized were: fishes, tadpoles, the herpetofauna and dragonfly larvae. The overall use of the restoration by dragonfly larvae, snails, fishes, amphibians, reptiles, and birds, was evaluated.

Because there is only one location with the two experimental treatments: complete soil removal (HIDA), and partial soil removal (HIDB), it was difficult to design an experimental framework for the study. Psuedoreplication was the most obvious difficulty to overcome (Krebs, 1989). Therefore, a series of sites for each natural habitat used in the comparison were chosen. One example of each of the natural habitats was randomly chosen for each sampling period (see Appendix 1 for more details). This permitted a wider range of natural conditions to be sampled Each sampling procedure was used in the two experimental areas, and in one example of each natural setting per sampling. For example, if sampling required the use of triplicate sets of minnow traps per site, then triplicates were done in each experimental site, and triplicates were done in one example of each of the other cover types per sampling.

Large numbers of wading birds, all the herons and egrets that are found in near by prairies and marshes, ibis, and woodstorks used HIDA and PONDB in HIDB. Other wetland birds that commonly used HIDA were killdeers, and greater yellow legs. HIDB was much less commonly used by wading birds. Additionally, sora rails were frequently seen at PONDB. The wading birds are so vagile and will use any water source for foraging, that I did not consider them a particularly sensitive group for addressing differences between the two restoration treatments. For this reason emphasis was placed on the use of the habitats by perching birds.

At each sampling the following data were collected: amphibian tadpoles, fishes, birds,, reptiles, amphibians, fishes, snails and dragonfly larvae).

Aquatic organisms were sampled by:

1. dip net (5 sweeps of the net) at three locations in each site.
2. seine net: one sweep at each of three locations within each site.
3. minnow traps: three sets of six traps were placed in each location, three of the traps were loaded with rocks to sample at the bottom of the water column, and three were allowed to float, to sample the surface waters.

Terrestrial fauna was sampled by:

1. Drift fences with funnel traps arrays. The arrays were identical to the ones used by Dalrymple (1988) to permit

easier comparisons to his data on wetlands, and the Brazilian pepper forests of the HID.

2. Small mammal live traps: 15 large (rat size), and 15 small (mouse size) traps were placed in pairs at 10 m intervals in each habitat sampling. Traps were baited with oats and peanut butter. Traps were opened at dusk and checked the following morning, for three consecutive nights, for a total of 45 trap nights per habitat per sampling. Traps were used on a quarterly basis, for a total of 180 trap nights per year. (Mammal trap data was lost in the hurricane of 1992, see limitations below).

3. Strip transects of 100 m were checked for mammal sign (tracks and scat) in each habitat each month. This method only gives a rough estimate of habitat use, and is restricted to habitats where visibility permitted.

4. Strip transects of 100 m for perching birds and smaller wetland birds (e.g. killdeer). Each bird sighted was identified, and the distance from the center line of the transect, and angle ( $0 - 90^{\circ}$ ) on either side of the transect was noted.

Taylor Slough was sampled regularly on both sides of the bridge over the Main Park Road, as Taylor Slough East (TSE) and Taylor Slough West (TSW). The transects were not started until the observer was 20 m from the edge of the road because it was noted that meadowlarks use the area near

the road at an unusual rate (this strip of habitat was sampled separately for another ongoing study). The transects in prairies and in Taylor Slough all followed a south to north compass bearing. Transects in HID all followed an east to west bearing.

#### Faunal Analyses.

Community composition of habitats for animal taxa was evaluated by use of a matrix of numbers of individuals per species, and with the raw data standardized (as proportions) to reduce the effects of absolute sample sizes between habitats. When faunal data for a given habitat were very low, or absent that habitat was not included in the analyses, but are listed in the tables of raw data.

Matrices of taxa by habitats were analyzed by multivariate techniques: cluster analysis and principle component analysis (Pielou, 1984; Krebs, 1989; Rohlf, 1993). Data was standardized by two methods: as percent of sample (proportion) for relative abundance, and as normal deviates (the mean subtracted from each sample value and then divided by the standard deviation). Cluster analyses were done on standardized data sets, using correlation matrices and, or euclidean distance measures of similarity (dissimilarity). The clustering method used was UPGMA (unweighted pair group method). Principal component analyses used standardized data sets, with correlation matrices, and the projection method on the eigenvectors of the matrix (Rohlf, 1993). Clusters

and PCAs were all performed with both the habitats, and the taxa treated as the OTUs.

The tadpole data was also analyzed as a absence/presence matrix (0/1 matrix). The data was placed in a correlation matrix using the simple matching (SM coefficient of Rohlf, 1993) coefficient:  $m/n$ , where  $m$  = number of matches for each pair, and  $n$  = total sample size. Tadpoles were chosen for this analysis, because it was felt that sampling tadpoles by dip net, seine, or minnow traps presented more potential for bias due to:

1. the schooling behavior of some species, and
2. the ephemeral nature of tadpole communities due to their short-lived larval periods (see below).

Bivariate analyses emphasized similarity of microhabitats for significant taxa.

Successional trends will require long-term monitoring to be established in the future. A final element of the analyses were recommendations for such monitoring programs, identifying taxa, trophic elements and community attributes that best serve in a monitoring program.

The data from strip transects for birds were analyzed using both the Hayne's and Modified Hayne's techniques (Krebs, 1989). Density was calculated on a per hectare basis for each transect performed in each habitat, and then the average and standard error of all transects by habitat were calculated for comparison.

Rarefaction curves, which plot cumulative species observed versus cumulative individuals sampled, were developed for surveys of fishes. The expected species richness from all habitats could then be compared for any standard sample size to standardized comparison. The rarefaction curves were calculated by the method of Simberloff (1972; also see Krebs, 1989) as:

$$E(S_n) = \text{ABSOLUTE SUM of } 1 - ((N - N_i)/n)/(N/n),$$

where  $E(S_n)$  = expected number of species in a random sample of  $n$  individuals

$S$  = total number of species in species  $i$

$N_i$  = number of individuals in species  $i$

$N$  = total number of individuals in collection =  $\text{SUM } N_i$

$n$  = value of sample size (number of individuals) chosen from standardization ( $n = \text{or } < N$ )

$N$  = number of combinations of  $n$  individuals that can be chosen from a set of  $N$  individuals =

$$N!/n!(N-n)!$$

### Limitations.

Sampling. The fact that the pond in HIDB, PONDB, was atypical of the surface elevation, and therefore the hydroperiod of this portion of the restoration, made it obvious that it should be sampled separately. Some species with longer hydroperiod, primarily permanently aquatic forms were only found in the restoration in this pond. When water levels reach the surface on the surrounding restoration,

some individuals of these more permanently aquatic species show up on the restoration. Even in the natural short hydroperiod prairies, more permanently aquatic species show up during high water levels as they disperse in the natural surface water sheetflow, so their should be no surprise in seeing them in the shorter hydroperiod portions of wetland restorations that are contiguous with longer hydroperiod areas (e.g. marshes and slough). However, the current study area is not contiguous with naturally occurring longer hydroperiod settings, and so the pond does influence species composition in a unique manner.

Sampling PONDB was easier said than done, however. The resident female alligator in the pond was always troublesome. It destroyed minnow traps, and made dip netting, and seine netting very difficult. Personal experience with alligators in my research in Shark Slough (Dalrymple, in press) indicated that relocating the alligator would not have proven very much, since another one would have found the pond soon enough. Moreover, the problem of alligators interfering with sampling was common to all willow heads, ponds, and marshes sampled and reduced the sample sizes available for comparison of species composition between habitats.

Sampling for aquatic organisms was also a problem in short hydroperiod prairies because of the more irregular natural surface conditions. The micro-kaarst topography of natural short hydroperiod prairies of the park made seine

netting and minnow trapping difficult. More of the overall sampling was dependent on dip nets that could be easily scooped in the deeper, lower holes and pits in these prairies. In comparison, HIDA was graded to an unavoidably unnaturally flat surface topography, which has led to a more constant surface water condition that easily allowed use of seines and minnow traps. Moreover, the early successional state of the HIDA wetland plant community result in much lower density and coverage by plants (cf. Dalrymple, et al, 1993), making use of nets and traps easier. For the above reasons, sample sizes for HIDA were usually higher for aquatic organisms in this site. In order to avoid the sample size effects, all of the multivariate assessments were performed on standardized data (see above).

Hurricane. Hurricane Andrew, August, 1992 brought sampling to an abrupt end. All of the drift fences and traps were destroyed or blown away. Some of the data records and computer files for the sampling were also lost or destroyed at my residence during the storm, especially frustrating was the loss of the mammal trapping data. It has taken longer than expected to recover computer files and analyses, and most data had to be completely re-entered and re-analyzed.

## RESULTS AND DISCUSSION

### Fishes

Seventeen species of fishes were sampled in the study (Table 1). The habitat with the highest species richness was HIDA with 13 species, followed by Prairie with 12. The lowest richness was found in HIDB. The most common centrarchid in HIDA was Lepomis gulosus, which is considered to be the centrarchid most common in seasonally flooded, as opposed to permanent wetlands in the Everglades region (Loftus and Kushlan, 1987).

The HIDA site had the largest sample size for fishes. In order to more fairly compare the results of sampling, rarefaction curves (for equal sample sizes) were calculated for each habitat. Marsh had the highest expected number of species, 11, in a standardized sample of 100 individuals, followed closely by Prairie and HIDA (Figures 1 and 2). Percent composition of the samples by habitat are shown in Figure 3.

Cluster analysis of the standardized fish data (based on raw data in Table 1), revealed a strong similarity between HIDA and Prairie, with HIDB also clustering tightly with these habitats (Figure 4). Pearson's product moment correlation, as an index of similarity between HIDA and Prairie was 0.989, and between HIDA and HIDB was 0.965. While the standardized data reflect these similarities, it should be emphasized that HIDB had little standing water,

and sampling was difficult, with an order of magnitude more individuals sampled in HIDA and Prairie than HIDB due to their longer hydroperiods. Gambusia holbrooki, Jordanella floridae, and Lepomis gulosus were dominant by numbers in these sites (Figure 5). Principal component analysis also reveals the strong similarity for standardized fish data among HIDA, Prairie, and HIDB (Figure 6 and 7).

[ A tangential note regarding the use of the name Gambusia holbrooki - mosquitofish - instead of the more commonly known name of Gambusia affinis. In 1988, Wooten et al (1988) described the southern U.S. populations as G. holbrooki, genetically, separating them from G. affinis. The confusion has grown since it is known that mosquito fish are sometimes purchased as G. affinis and released in mosquito control programs, thus making the genetics of this species confusing.]

### Tadpoles

Eleven species of anuran larvae were sampled during the study. Nine species were found in Prairie, Marsh, and HIDA. The lowest number of species, 5, was found in Pond B (Table 2, Figure 8). The dominant species by numbers and habitat usage was the exotic Cuban tree frog, Osteopilus septentrionalis, followed closely by the southern toad, Bufo terrestris. Cuban tree frogs, southern toads, and oak toads (Bufo quercicus) were most abundant in the raw data in

Prairie and HIDA, and pigfrogs (Rana grylio) were most common in PONDB, Marsh, and cypress dome (Figures 8).

As mentioned in the methods section, the tadpole data was analyzed as a similarity matrix of absencedata (0/1), to avoid bias. When this matrix was analyzed by Cluster Analysis, HIDA showed a strong correlation with Prairie. HIDB clustered closest with hammock solution holes, and then with PONDB, marsh and cypress dome (Figures 9 and 10). The PCA of this matrix shows Prairie and HIDA grouped closely, while Marsh, cypress dome, hammock solution holes and HIDB are more similar, as in the clustering. PONDB is the most distinctive (Figure 11).

#### Tadpoles and adult anurans.

Frogs and toads are ubiquitous breeders in the Everglades. While most species will breed in almost any aquatic setting, they are not always equally successful in the different habitats. The eggs of all of the anurans in the Everglades develop rapidly due to the high water temperatures; the range of days required for eggs of our local species to hatch is only 1 to 6 days (Wright, 1932; pers. obs.). Some small, short-lived, species such as the oak toad, Bufo quercicus, have very short developmental periods. In the oak toad it takes only 25 to 30 days for the larva to metamorphose (Volpe and Dobie, 1959). At the other extreme, the pig frog, Rana grylio larvae require 365 or more days to metamorphose (Wright, 1932; pers. obs.). Given

these extremes it should be clear that some species are effectively excluded from some habitats not by adult use but by reproductive success: the larvae simply do not have enough time to develop to metamorphic stage.

The tadpole species composition of the habitats varied with hydroperiod (Figure 8A). The average duration of the larval period (from Wright, 1932) for the species is plotted in Figure 8B to demonstrate the need for permanent water only in R. grylio. Rana grylio tadpoles were most common, (largest percent of total sample) in the three habitats with the longest hydroperiods, marshes, cypress domes, and Pond B. While this species probably lays eggs in many wetland settings, adults are most common in areas that are flooded year round, and larvae will only succeed in such habitats. During the late wet season, when water levels are highest, some Rana grylio tadpoles are seen in short hydroperiod prairies (pers. obs.), as they disperse with surface water flow, but they either get back to deep water habitats, or they die when water levels drop.

Some tadpole species are thought to be sensitive to competition and, or predation from fishes; and clearly some temporal isolation does take place in habitat use. For example, in the early spring when water first reaches the surface of prairies and the restoration site, frogs call in massive numbers and large numbers of eggs are laid. For nearly two months the dominant aquatic vertebrates are tadpoles. These herbivores, and scavengers quickly recycle

old periphyton and blooming algae and create conditions that may be critical to wetland dynamics later in the season. By mid summer the tadpoles are mostly metamorphosed and the dominant vertebrates are fishes, herbivores, scavengers, and predators.

The predominance of exotic Cuban tree frog, Osteopilus septentrionalis, in the HID was documented by Dalrymple (1988), and the species range in the park continues to expand. Both adult and larval Osteopilus are one of the dominant anurans in the HID restoration area. Competition for food between native tadpoles and this species' is probably not important in the HIDA restoration in most years, because the primary productivity of algae is extremely high. However, it could be a problem in drought years. Until much more research is done on this species, we should consider it a possible serious problem. Adult Cuban tree frogs readily eat native tree frogs (pers. obs.). The adults have copious amounts of noxious secretions, the adults are not eaten by many native frog predators, including birds and snakes (pers. obs.), and the eggs and larvae of this species might also be noxious.

#### Salamanders.

Salamanders were not observed in the restoration area during the study. The siren, Siren lacertina, is only commonly observed in permanent water settings or during very high water conditions near such sites, so its absence in the

HIDA area is not unexpected. Amphiuma means, the congo eel, was common in prairies. As many as six were trapped in minnow traps in one week in a prairie willow head during low water. During high water periods they can be seen foraging at night in water as shallow as 4 cm. Notophthalmus viridescens, the striped newt, was common in cypress domes, marshes, and in a few (permanent water) hammock solution holes. Neither Amphiuma or Notophthalmus were observed in the restoration area. It may take longer for the salamanders to reach and establish themselves in these restored wetlands than it takes the more vagile, and more terrestrial anurans.

#### Herpetofaunal trapping.

Twenty two species of amphibians and reptiles were trapped in HIDA. A total of 184 animals were captured, at a rate of 0.93 animals per check day. HIDB had 19 species and 274 animals trapped, at a rate of 0.81 animals per check day. The drift fence trapping by Dalrymple (1988, attached as Appendix 2) in HID Brazilian pepper forests (described as "disturbed" areas = DIST, by Dalrymple) captured 21 species at a rate of 0.76 animals per check day (Table 3). In prairies, Dalrymple (1988) captured 30 species at a rate of 1.04 animals per check day. HIDA and HIDB had species richness and capture rates more similar to Brazilian pepper forest than prairies, but the species composition of the two restoration areas was quite different.

Cluster analysis of the data collected in the current study was performed with the data collected by Dalrymple (1988) for the HID Brazilian pepper forest (DIST) and prairies. HIDA clustered with prairies, while HIDB clustered with the Brazilian pepper forest (DIST; Figure 12). Prairie showed no significant correlation with Brazilian pepper in Dalrymple's (1988) trapping ( $r = 0.145$ ). The correlation coefficient (as a similarity index) was significant, 0.745, between HIDA and Prairie, and 0.583 between HIDA and HIDB. The highest correlation was between HIDB and Brazilian pepper forest (DIST) was very high, 0.933.

The green anole, Anolis carolinensis, was much more common in prairies than HID. The exotic brown anole, Anolis sagrei, was very common in Brazilian pepper (DIST, Dalrymple, 1988; Table 3) and was also trapped in both HID restoration areas. The ground skink, Scincella laterale, was common in prairies, and 2 were trapped in HIDA, but none were trapped (or seen) in HIDB or Brazilian pepper.

Three major groupings are seen in cluster analysis for the trapped species (Figure 13). The top cluster is of species that are primarily found in prairies. The middle cluster is of species common to the prairies, and the restorations, including the oak toad, the striped mud turtle, and the ground skink. The bottom cluster is species that are dominant in Brazilian pepper (DIST), including the brown anole, and the Cuban tree frog.

The narrow mouthed frog, Gastrophryne carolinensis, was common in Brazilian pepper, and also HIDB. This species is an ant eater, and appears to prefer areas with rich soil. The partial soil removal in HIDB is probably part of the reason why this species is more common there than on HIDA.

Principal component analysis of the drift fence data with the data from Dalrymple (1988), also shows HIDB grouping closer to Brazilian pepper (DIST), however the PCA shows the similarity between HIDA and HIDB more clearly (Figures 14 and 15). The prairie has a number of wetland species that have not shown up (at least till now) in the restorations including the salamanders. A number of species are probably missing from HIDA and HIDB because they are not adjacent to upland pinelands from which many species seasonally move out into adjoining prairies (Dalrymple, 1988; see discussion) especially a number of snakes (Lampropeltis triangulum, Cemophora coccinea, Drymarchon corais), and the box turtle (Terrapene carolina). The cricket frog (Pseudacris nigrita) is generally considered an edge species between pinelands and prairies (Duellman and Schwartz, 1958; Wilson and Porras, 1983; Dalrymple, 1988).

In the PCA, the most distinctive habitats are the prairie and Brazilian pepper, with the restorations lumped in between, and strongly influenced by the presence of the exotic brown anole (Anolis sagrei) and Cuban tree frog (Osteopilus septentrionalis), the narrow mouthed frog

(Gastrophryne carolinensis), and the absence of the upland seasonal users (above).

Although not trapped, the rough green snake (Opheodrys aestivus) was seen several times in HIDB. Because this is a highly arboreal species, it is rarely trapped. Dalrymple (1988) never trapped even one of this species in three years in adjacent Brazilian pepper or natural habitats). This species was regularly seen basking in mid-day on the Research Road adjacent to the Brazilian pepper forests throughout the HID (Dalrymple, Steiner, Bernardino, and Nodell, 1991). Its presence in HIDB but not HIDA is another indication of the thick shrubby nature of HIDB.

### Birds

The highest species richness from strip transects was found in HIDB, with 11 species; HIDA had the second highest richness with 9 species. Taylor Slough (broken into two parts, see methods) east (TSE) had 3 species and west (TSW) had 4 species. Prairies had the lowest richness value, one species (Table 4). The greatest number of birds seen on transects was at HIDA with 98. followed by HIDB with 89. By comparison the two marsh sites (TSE and TSW) had 10 and 20 individuals, respectively, and Prairies had only 2 birds seen along transects.

Estimates of bird habitat use from the above strip transect data were based on Hayne's method of calculating density. HIDB had the highest average density per hectare of

birds by an order of magnitude: 250 (+/- 4); followed by HIDA with 12 (+/- 10), TSW with 3 (+/- 2), and TSE with 0.9 (+/- 0.5). The reason for the much higher density estimate for HIDA is due to the much shorter average distance from observer to birds along the strip transect (see below).

When species richness, raw data, and density estimates are combined the conclusion is that there are more kinds of birds and higher densities in the HID restoration than in the natural wetland prairies or marshes (or in the Brazilian pepper forests of the HID, see Curnutt, 1989). The HIDA has such a high density estimate because so many birds were spotted at shorter distances along transects. HIDA has a more complicated pattern of emergent herbaceous and woody species than do the prairies and marshes, and this in particular draws in the red winged blackbirds, cardinals, common yellow throats, palm warblers, savannah sparrows, grackles, white eyed vireos, and wrens. Bobolinks pass through the park as migrants, and were noted in smaller groups in prairies (but not during transect counts). For the above reasons the HIDA is structurally more like a wooded wetland setting, than a prairie.

#### Dragonfly Larvae

Identification of dragonfly larvae was restricted to the genus level, in some cases, for two reasons. Firstly, uncertainties still exist for current species level status in southern Florida. Secondly, the ecological habits, and

habitat preferences for dragonfly larvae are well documented at the genus level due to gross morphological adaptations for locomotion, predation, and respiration, all of which reflect wetland conditions (Westfall, 1984).

Fourteen taxa of dragonfly larvae were identified in the study. Seven genera were found in Cypress Dome and HIDB, 6 in Prairie, and 5 in HIDA. Three taxa were found in the large marl pond in Palma Vista 1 Hammock, and in PONDB (Table 5, Figure 16). Only one species was found in Pineland solution hole.

Cluster analyses and PCA's for the dragonfly larvae by habitats showed that HIDA was most similar to Prairie, while HIDB and POND B were most similar to Cypress Dome (Figure 17 - 20). The findings for HIDA and Prairie similarity are similar to those found for found for fishes, tadpoles, and drift fence data.

#### Snails.

The species lists for snails collected are listed in Table 6. Four species were found in wetland samplings: Fossaria cubensis, Physella cubensis, Polygyra septemvolva, Polygyra uvifera, and Pomacea paludosa. The most important point to note is that the apple snail was not collected in HIDA or HIDB. Even if this species is present in the study areas, it occurs in low enough numbers to date, that they never showed up in sampling, not even in seine nets or minnow traps. HIDA had twice as many snail species as HIDB, reflecting the longer hydroperiod in the former site. The

absence of apple snails in HIDA, while they are common in prairies, is another reflection of the isolation of the restoration from contiguous wetlands.

## SUMMARY AND CONCLUSIONS

Scientific restoration (Howell, 1988) requires re-establishment of both natural structure and function. The abiotic and biotic components, including the floral and faunal species lists and community organization (biomass, density, importance) must be as close to natural as possible (Landin, Clairain, and Newling, 1989). The functional characteristics of the ecosystem (energy flow, nutrient cycling, hydrology, and food chains) must also be restored in order to call a restoration successful from the point of view of national park conservation policy and philosophy (Cairns, 1986).

Without careful analysis of successional processes at on-going restoration sites, we will not be able to determine methods for improvement of restoration technique in future plans for the **HID**. The patterns of colonization by wetland plants in the existing restoration effort in the **HID** are being studied in depth, but establishment of natural ecosystem structure and function in restored wetlands will require knowledge of both floral and faunal assemblages. At the present time there is no program for analysis of the patterns of faunal colonization and successional dynamics.

The annual flooding of short-hydroperiod prairies is characterized by periphyton bloom dominated first by blue-green algae and latter into the summer and deeper flooding by green algae. Tadpoles, as a major herbivore, play a major role in periphyton community dynamics (Dickman, 1968) and

may be limited in restored wetlands by altered periphyton community composition. Browder (1981) showed strong correlations between soil organic matter, water depth and periphyton composition in Everglades wetlands. The basic relation between soil development and periphyton activity in the early stages of restoration of short-hydroperiod prairies coupled with the fact that soil development in the graded HID restoration is in early stages, suggests that the **HID** restoration area probably has a distinctive community dynamic at this time.

#### Faunal Associations

The "infaunal" elements (cf. Harris, 1988) were more likely to determine the natural pattern of succession than were highly vagile species, such as wading birds and large mammals. However, complete lists of species using the restoration sites and the nature of usage (nesting, foraging) were developed and compared to natural wetland sites in the vicinity to determine whether the restorations provide any distinctive advantages or disadvantages (seasonal, short term, or long term) to such species.

The fresh water in-fauna includes transitory users, such as tadpoles and insect larvae, permanent users such as salamanders, fishes and crayfish. The duration of use is not a good measure of the ecological importance of the in-fauna. For example, the tadpoles are rapidly eating and growing early in the wet season before much of the periphyton mat is

developed. They play a vital role in moving nutrients quickly into the aquatic systems they scrape up much of the substrate in feeding, and they produce copious amounts of poorly digested feces. The tadpoles also serve as an important early food for fresh water predators such as dragonfly larvae, beetles, crayfish, Amphiuma, and even some fishes. Many of the same predators will shift to other prey including each other as the wet season continues. The tadpoles also play a major role in moving aquatic nutrients into the uplands, as they metamorphose and disperse from water.

Analysis of dragonfly larvae, snails, fishes, amphibians and reptiles, and birds, make it clear that complete soil removal and grading, as seen in HIDA, resulted in a longer hydroperiod, higher overall productivity of plants and animals, a fauna much more similar to a short hydroperiod prairie, than did partial soil removal. Limitations in potential ultimate faunal similarity between HIDA and natural prairies, is a function of the isolation of the current restoration. Without direct contact with marshes of longer hydroperiod, some fully aquatic faunal components will not be found in the restoration. Without direct contact with natural uplands, pinelands, the seasonal use of this emerging wetland will remain limited (e.g. Dalrymple, 1988, noted that 30% of the herpetofauna that use prairies also use pinelands). Finally, the isolation of the site and the fact that it is surrounded by Brazilian pepper forest

results in a continual invasion of the area by exotic species that are most common in the disturbed agricultural area. While this site was chosen for convenience with regard to access, it is clear that future efforts to restore wetlands in the HID would more rapidly reflect natural short hydroperiod prairies, if they were planned so that they are in direct contact with natural communities: restoration from the "outside in", rather than from the "inside out".

## LITERATURE CITED

- Berger, J.J. 1993. Ecological restoration and non-indigenous species: a review. *restoration Ecology* 1:74-82.
- Browder, J.A. 1981. Perspective on the ecological causes and effects of the variable algal composition of southern everglades periphyton. South Florida Research Center Technical report T-643. Everglades National Park, Homestead, FL.
- Cairns, J. Jr., 1986. Restoration, reclamation, and regeneration of degraded or destroyed ecosystems. Pages 465-484 in: *Conservation Biology, The Science of Scarcity and Diversity*, edited by M.E. Soule. Sinauer Associates. Sunderland, Mass.
- Curnutt, J.L. 1989. Breeding bird use of a mature stand of Brazilian Pepper. *Florida Field Naturalist*. 17: 53-60.
- Dalrymple, G. H. 1988. The herpetofauna of Long Pine Key, Everglades National Park, in relation to vegetation and hydrology. In "Management of Amphibians, Reptiles, and Small Mammals in North America", pp. 72-86. R. Szaro, K.E. Severson, and D.R. Patton, tech. coordinators. U.S.D.A. Forest Service. General Technical Report RM-166. Fort Collins.
- Dalrymple, G.H., T.M. Steiner, R.J. Nodell and F.S. Bernardino, Jr. 1991. Seasonal activity of the snakes of Long Pine Key, Everglades National Park. *Copeia* 1991:294-302.
- Dalrymple, N.K, G.H. Dalrymple, and K.A. Fanning. 1993. Vegetation of restored rock-plowed wetlands of the east Everglades. *Restoration Ecology* 1:220-225.
- Dickman, M. 1968. The effect of grazing by tadpoles on the structure of a periphyton community. *Ecology* 49: 1188-1190.
- Doren, R. and L. Whiteaker. 1988. Plan for mitigation of secondary successional communities in Everglades National Park: Hole-in-the-Donut. Everglades National Park. In-house Report. 17 pp.
- Duellman, W. E., and A. Schwartz. 1958. Amphibians and reptiles of southern Florida. *Bull. Florida St. Museum* 3:181-324.

- Ewel, J.J., D.S. Ojima, D.A. Karl, and W.F. DeBusk. 1982. Schinus in successional ecosystems of Everglades National Park, Homestead, Florida. Everglades National Park, South Florida Research Center Report. T-676.
- Harris, L.D. 1988. The nature of cumulative impacts on biotic diversity of wetland vertebrates. Environmental Management. 12:675-693.
- Howell, E. 1988. The role of restoration in conservation biology. Endangered Species Update. 5:1-4.
- Krauss, P. 1987. Old field succession in Everglades National Park. Report SFRC-87/03. South Florida Research Center.
- Krebs, C.J. 1989. Ecological Methodology. Harper and Row. New York. 654 + xii.
- Landin, M.C., E.J. Clairain, and C.J. Newling. 1989. Wetland habitat development and long-term monitoring at Windmill Point, Virginia. Wetlands 9:13-25.
- Loftus, William F. and James A. Kushlan. 1987. Freshwater fishes of southern Florida. Bulletin of the Florida State Museum, Biological Sciences. 31:147-344.
- Pielou, E.C. 1984. The interpretation of ecological data. John Wiley and Sons. New York. 236+xi.
- Rohlf, F.J. 1993. NTSYS-pc. Numerical Taxonomy and Multivariate System. version 1.80. Exeter Publ. Setauket. New York.
- Volpe, E.P. and J.L. Dobie. 1959. The larva of the oak toad, Bufo quercicus Holbrook. Tulane Studies in Zoology 7:145-152.
- Westfall, M.J. Jr. 1984. Odonates. pp 126-176 In "An introduction to aquatic insects" 2 ed., pp. 126-176, R.W. Merrit and K.W. Cummins. Kendall, Hunt Publ. Co. Dubuque, IA.
- Wilson, L.D., and L. Porras. 1983. The ecological impact of man on the south Florida herpetofauna. Mus. Nat. Hist. Univ. Kans. Special Publ. 9.89 + vi.
- Wooten M.C., K.T. Scribner, and M.H. Smith. 1988. Genetic variability and systematics of Gambusia in the southeastern United States. Copeia: 1988:283-298.
- Wright, A.H. 1932. Life histories of the frogs of Okefinokee Swamp, Georgia. MacMillan Co., New York, 497 pp.

Table 1. Species list, and sample sizes for fishes by habitats. Codes are used in figures: Species codes are listed t the end of each row. Habitat codes are listed as columns. PSH = Pineland solution hole; PRA = prairie; CD = cypress dome.; TS = marsh at Taylor Slough.

	TS	HIDA	PONDB	HIDB	PSH	PRA	CD	Code
<i>Belonesox belizanus</i>	1	2	0	3	0	3	3	Bb
<i>Cichlasoma bimaculatum</i>	0	4	0	0	0	29	1	Chi
<i>Clarias batrachus</i>	0	5	2	5	0	0	0	Cba
<i>Cyprinodon variegatus</i>	0	4	0	0	0	0	0	Cv
<i>Fundulus chrysotus</i>	3	7	18	1	0	4	0	Fch
<i>Fundulus confluentus</i>	2	20	0	0	0	5	7	Fco
<i>Gambusia affinis (holbrooki)</i>	4	441	9	34	18	204	19	Ga
<i>Heterandria formosa</i>	4	18	2	0	0	5	0	Hf
<i>Ictalurus nebulosus</i>	0	0	0	0	0	4	0	In
<i>Jordanella floridae</i>	8	307	35	34	0	162	56	Jf
<i>Labidesthes sicculus</i>	1	0	0	0	0	0	0	Ls
<i>Lepomis gulosus</i>	1	12	22	3	1	5	9	Lgu
<i>Lepomis macrochirus</i>	0	0	0	0	0	2	0	Lm
<i>Lucania goodei</i>	0	36	2	1	0	12	6	Lgo
<i>Poecilia latipinna</i>	26	48	2	0	0	13	3	Pl
<i>Tilapia mariae</i>	6	1	3	0	2	0	0	Tm

TABLE 2. Species list for tadpoles by habitat. P.S.H. = pineland solution hole; H.S.H = hammock solution hole. Codes are used in figures for abundance by habitat and multivariate analyses

	<u>Prairie</u>	<u>Marsh</u>	<u>Cypress</u>	<u>P.S.H</u>	<u>H.S.H.</u>	<u>HIDA</u>	<u>HIDB</u>	<u>PONDB</u>	<u>Code</u>
Rana									
grylio	0	23	12	0	0	0	0	18	Rg
Rana									
sphenocephala	1	12	9	0	6	7	4	2	Rs
Hyla									
cinerea	2	6	5	0	5	3	5	4	Hc
Hyla									
squirella	2	5	5	0	6	3	5	4	Hs
Limnaoedus									
ocularis	6	7	8	10	0	12	0	0	Lo
Osteopilus									
septentrionalis	22	21	0	32	21	22	32	0	Os
Pseudacris									
nigrita	1	12	0	10	0	0	0	0	Pn
Acris									
gryllus	0	0	21	0	0	22	12	0	Ag
Gastrophryne									
carolinensis	4	6	0	25	22	9	30	0	Gc
Bufo									
terrestris	12	0	12	23	32	25	23	19	Bt
Bufo									
quercicus	12	23	0	9	0	9	0	0	Bq

TABLE 3. Total numbers of amphibian and reptile species trapped in arrays (Prairie and Brazilian pepper dominated HID = Disturbed (DIST) data collected from May '84- Dec '86; HIDA and HID B data collected from June '91 to June '92). Totals are combined for all arrays in each habitat type. "Check-days" are the number of days on which a trap was checked for animals. Codes are used in figures for multivariate analyses.

Species	Habitats				Codes
	Prairies	HIDA	HIDB	DIST	
1. <i>Amphiuma means</i>	9	0	0	0	Am
2. <i>Acris gryllus</i>	1	2	0	0	Ag
3. <i>Bufo quercicus</i>	95	31	12	9	Bq
4. <i>Bufo terrestris</i>	45	10	6	31	Bt
5. <i>Eleutherodactylus planirostris</i>	15	3	7	6	Ep
6. <i>Gastrophryne carolinensis</i>	10	13	22	33	Gc
7. <i>Hyla cinerea</i>	20	3	0	3	Hs
8. <i>Hyla squirella</i>	32	2	1	4	Hc
9. <i>Osteopilus septentrionalis</i>	2	7	9	6	Os
10. <i>Pseudacris nigrita</i>	5	0	0	0	Pn
11. <i>Rana grylio</i>	5	0	1	0	Rg
12. <i>Rana sphenoccephala</i>	135	32	16	20	Rs
13. <i>Anolis carolinensis</i>	170	22	12	19	Ac
14. <i>Anolis sagrei</i>	0	23	42	103	As
15. <i>Eumeces inexpectatus</i>	23	1	2	3	Ei
16. <i>Ophisaurus compressus</i>	1	0	0	1	Oc
17. <i>Scincella laterale</i>	30	2	0	0	Sl
16. <i>Kinosternon bauri</i>	12	5	2	1	Kb
19. <i>Terrapene carolina</i>	11	3	2	3	Tc
20. <i>Agkistrodon piscivorus</i>	1	1	2	2	Ap
21. <i>Cemophora coccinea</i>	2	0	0	0	Ce
22. <i>Coluber constrictor</i>	8	4	6	14	Cc
23. <i>Diadophis punctatus</i>	3	2	1	0	Dp
24. <i>Drymarchon corais</i>	1	0	0	0	Dc
25. <i>Elaphe obsoleta</i>	0	0	0	1	Eo
26. <i>Lampropeltis triangulum</i>	1	0	0	0	Lt
27. <i>Nerodia fasciata</i>	3	1	0	0	Nf
28. <i>Regina alleni</i>	1	0	0	0	Ra
29. <i>Sistrurus miliarius</i>	14	3	1	6	Sm
30. <i>Storeria dekayi</i>	2	0	0	0	Sd
31. <i>Thamnophis sauritus</i>	8	3	2	0	Tsau
32. <i>Thamnophis sirtalis</i>	30	11	6	7	Tsi
Totals	695	184	152	274	
No. Check-days	669	197	187	361	
Animals/Check-day	1.04	0.93	0.81	0.76	
No. Species	30	22	19	21	

Table 4. Species lists for birds observed during strip transects by habitat.

	HIDA	HIDB	TSW	TSE	PRAIRIE
Palm warbler	12	3	0	0	0
Savannah sparrow	17	13	0	0	0
Common yellow throat	1	37	0	1	0
Red winged black bird	35	16	8	5	0
Catbird	0	3	0	0	0
Carolina wren	0	1	0	0	0
White eyed vireo	1	9	0	0	0
Meadowlark	3		10	4	2
Cattle egret	0	1	0	0	0
Common grackle	0	0	1	0	0
American egret	9	0	0	0	0
Bobolink	18	0	0	0	0
Spotted sandpiper	0	1	0	0	0
Cardinal	2	2	0	0	0
Green backed heron	0	3	0	0	0
Total species	9	11	4	3	1
Total indiv.	98	89	20	10	2

Table 5. Number of dragonfly larvae collected by habitat.  
 Codes are used in figures that represent multivariate analyses.

Species	HIDB	HIDA	PONDB	PRAIRIE	CYPRESS	HSB	PSH	Code
Anax sp.	24	40	2	8	3	0	0	An
Arigomphus pallidus	0	0	0	3	1	0	0	Ap
Celithemis sp.	4	0	0	0	0	0	0	Ce
Coryphaeschna sp.	1	0	0	0	4	0	0	Co
Gynacantha nervosa	0	0	0	0	0	0	2	Gn
Ladona deplanata	0	2	0	0	0	0	0	Ld
Libellula sp.	24	17	4	3	8	0	0	Li
Nasiaeschna pentacantha	0	0	0	0	1	2	0	Np
Orthemis ferruginea	1	0	0	0	0	0	0	Of
Pantala sp.	21	1	0	1	0	0	0	Pa
Perithemis sp.	0	0	0	1	0	0	0	Pe
Pachydiplax longipennis	0	11	0	9	1	5	0	Pl
Tramea sp.	9	0	1	0	1	0	0	Tr
Triacanthagyna trifida	0	0	0	0	0	1	0	Tt
Total species	7	5	3	6	7	3	1	
Total Individ.	84	71	7	25	17	8	2	

Table 6. Species list for snails collected in sampling.

HID A:

*Fossaria cubensis*  
*Physella cubensis*  
*Polygyra septemvolva*  
*Polygyra uvifera*

HID B:

*Physella cubensis*  
*Polygyra septemvolva*

POND B:

*Fossaria cubensis*  
*Physella cubensis*  
*Poylgyra uvifera*  
*Polygyra septemvolva*

TAYLOR SLOUGH:

*Biomphalaria havanensis*  
*Physella cubensis*  
*Polygyra septemvolva*  
*Pomacea paludosa*

CYPRESS DOMES

*Biomphalaria havanensis*  
*Physella cubensis*  
*Polygyra septemvolva*  
*Pomacea paludosa*

HAMMOCK S.H.:

*Polygyra septemvolva*

PRAIRIES

*Fossaria cubensis*  
*Physella cubensis*  
*Polygyra sepetmvolva*  
*Pomacea paludosa*

Figure 1. Rarefaction curves for species richness of fishes by habitat.

# RAREFACTION OF FISHES

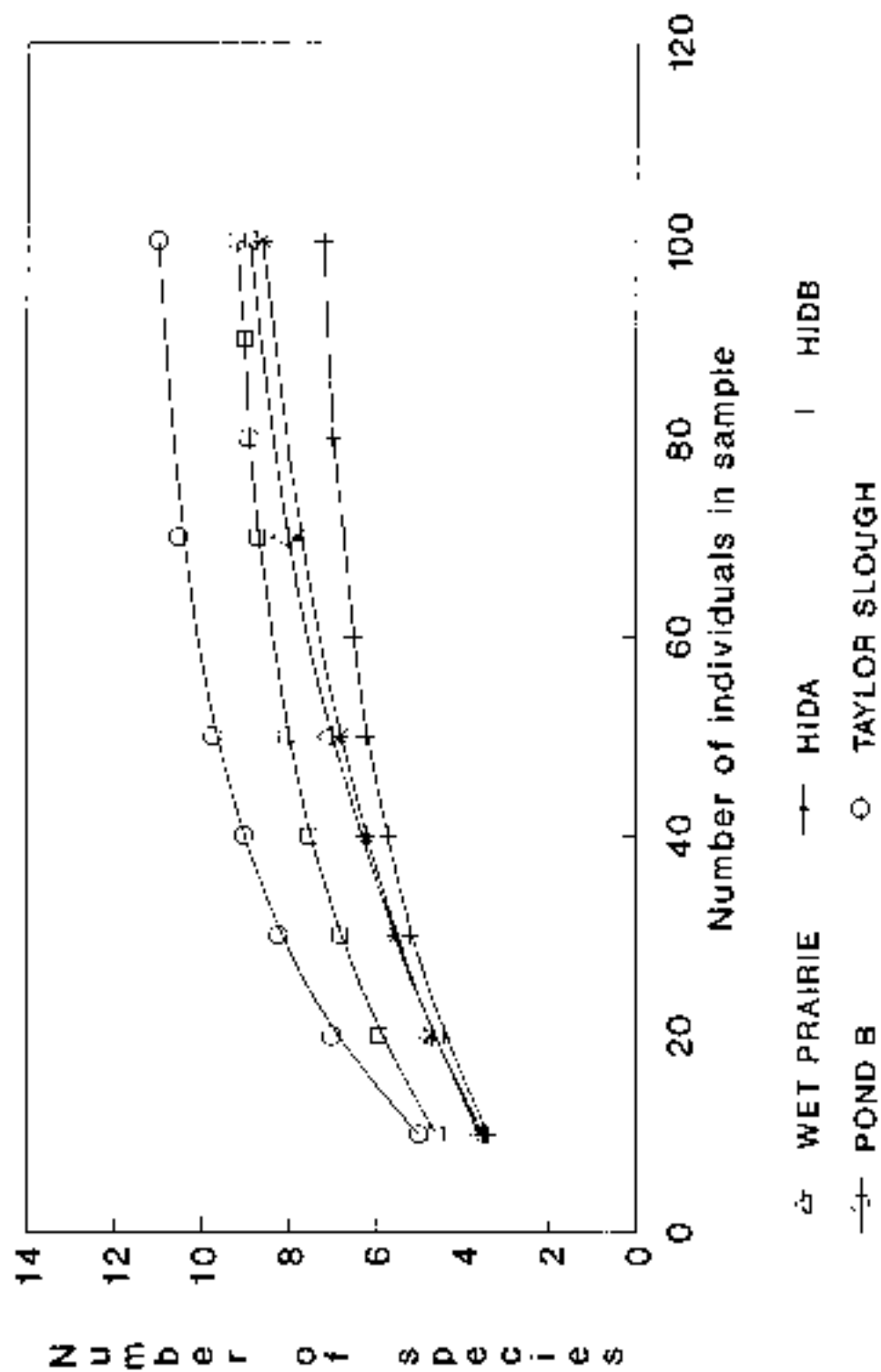
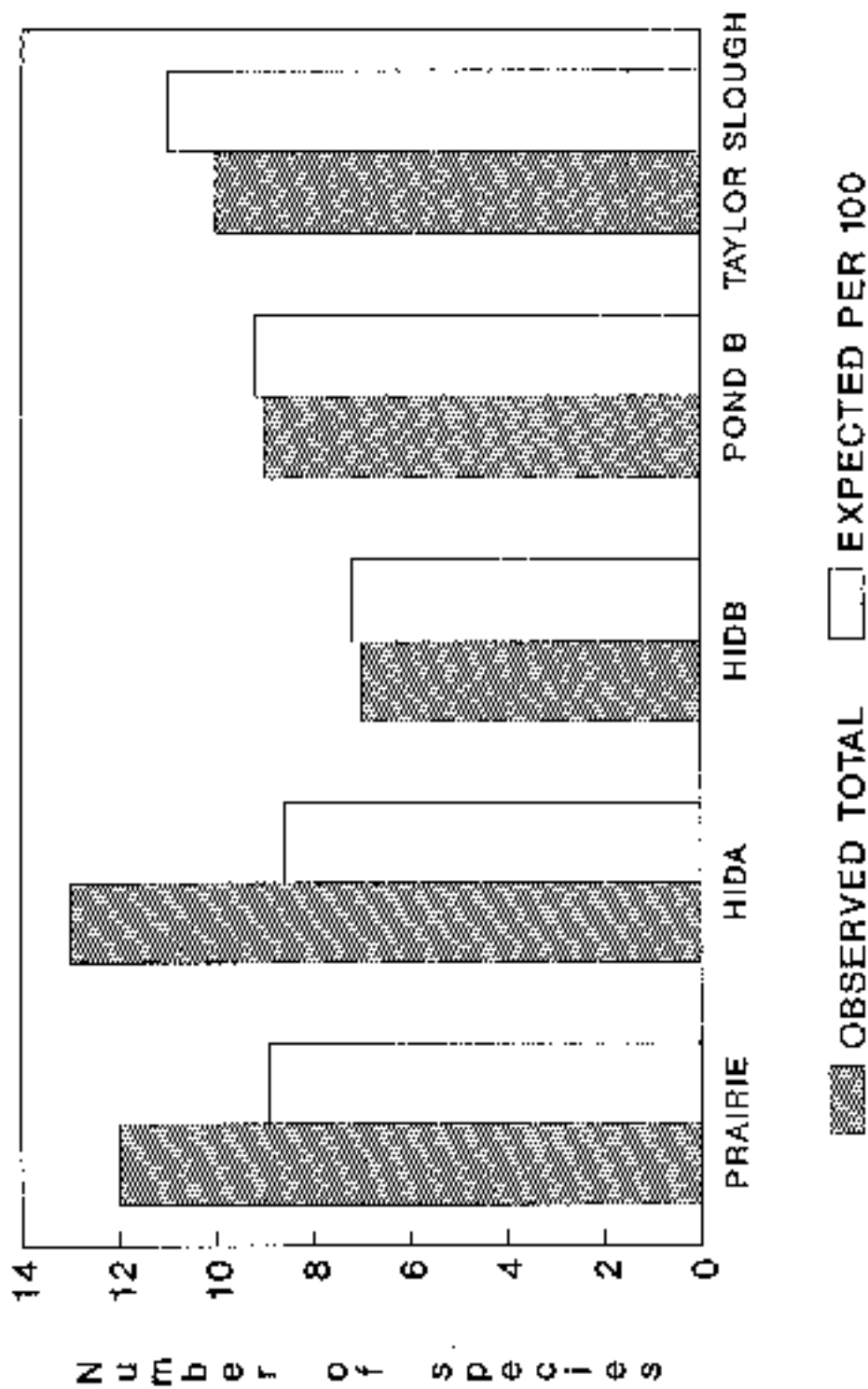

Figure 2. Observed species richness in samples of fishes by habitat, and expected (from rarefaction curves) number of species in samples of 100 fishes.

**SPECIES RICHNESS - FISHES**  
OBSERVED VS. EXPECTED



EXPECTED VALUES FROM RAREFACTION

Figure 3. Percent composition of habitat samples for fishes sampled (Codes from Table 1).

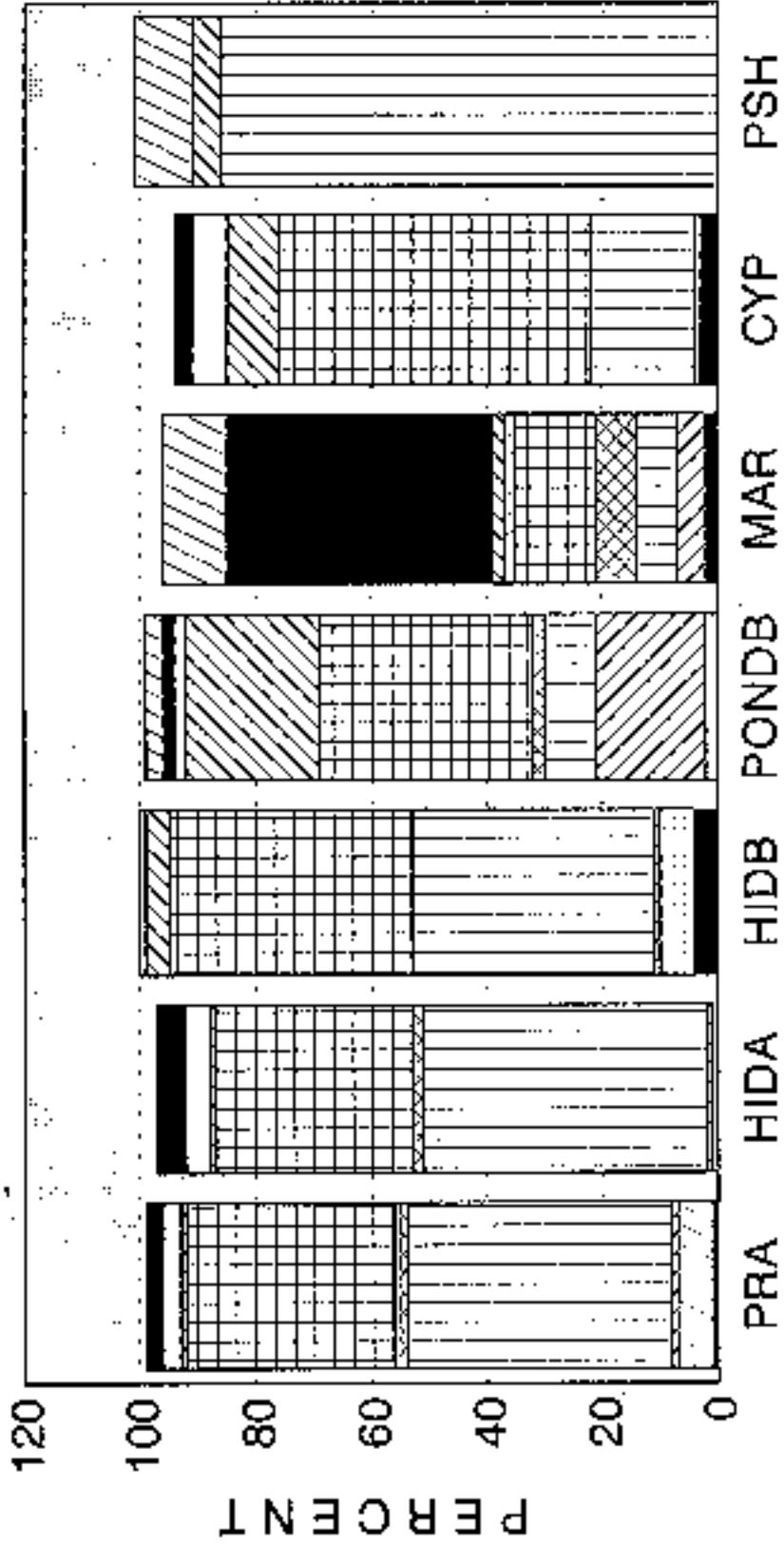

H A B I T A T



Figure 4. Cluster analysis of habitats using standardized data for fish samples by habitat (data and codes are from Table 1).

# HABITATS FOR FISH DATA

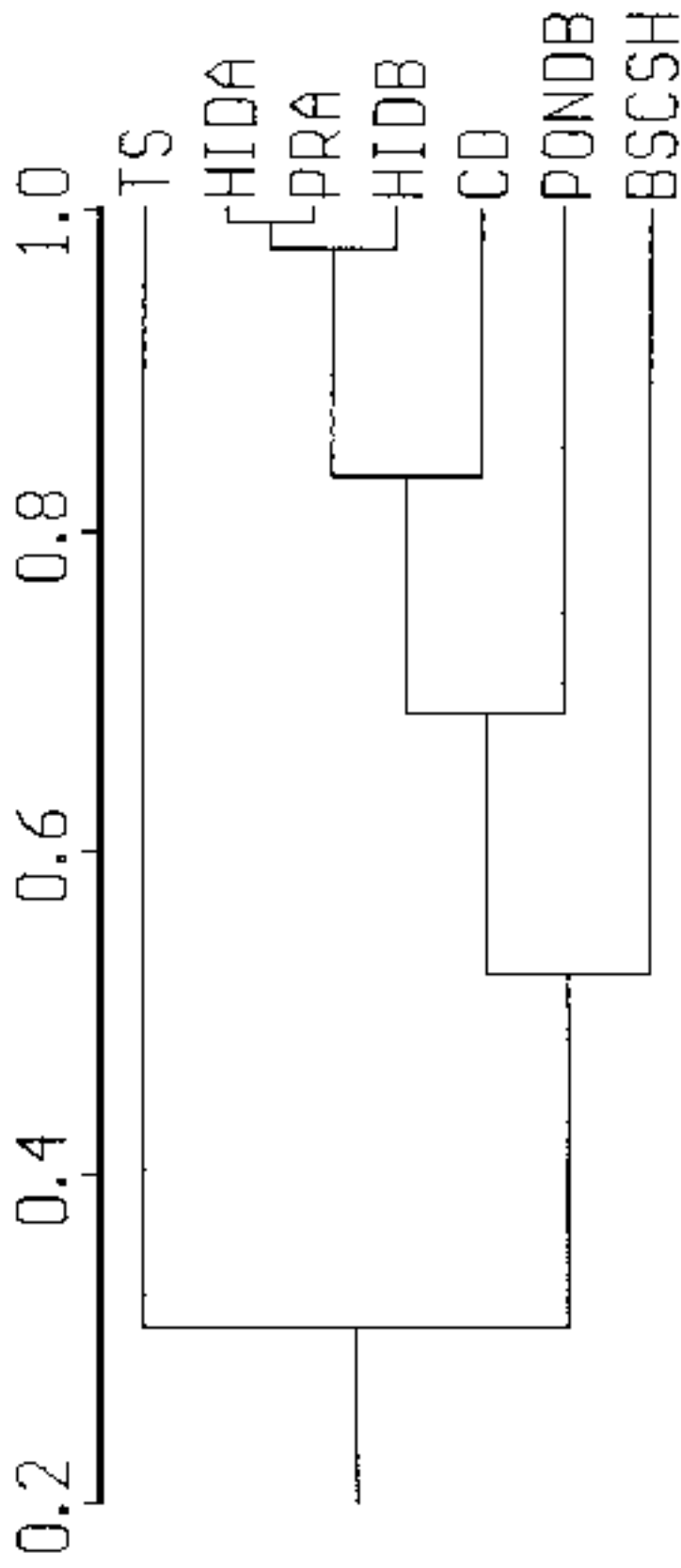

Figure 5. Cluster analysis of standardized data for fishes by taxa (data and codes are from Table 1).

# UPGMA CLUSTER FISHES

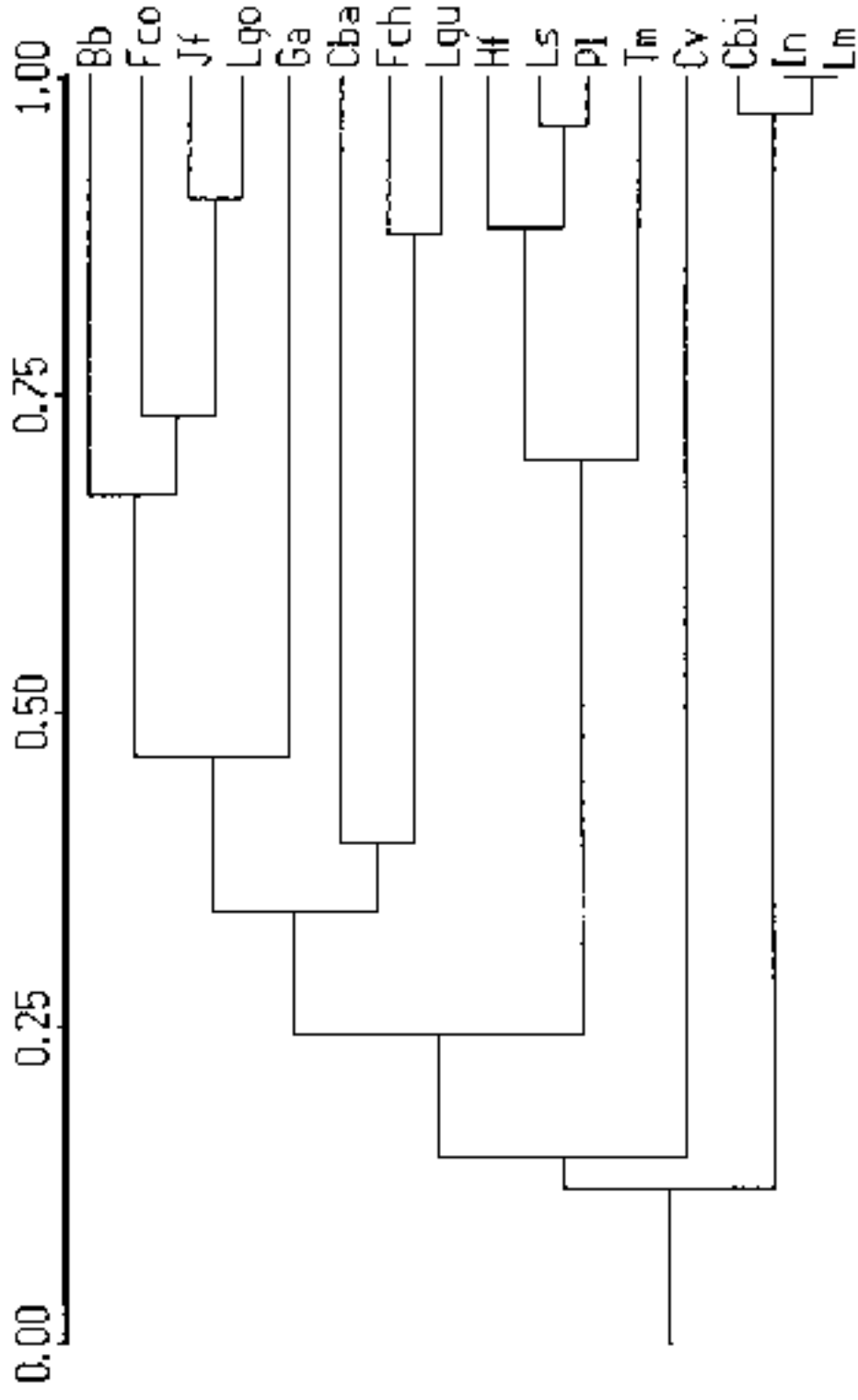
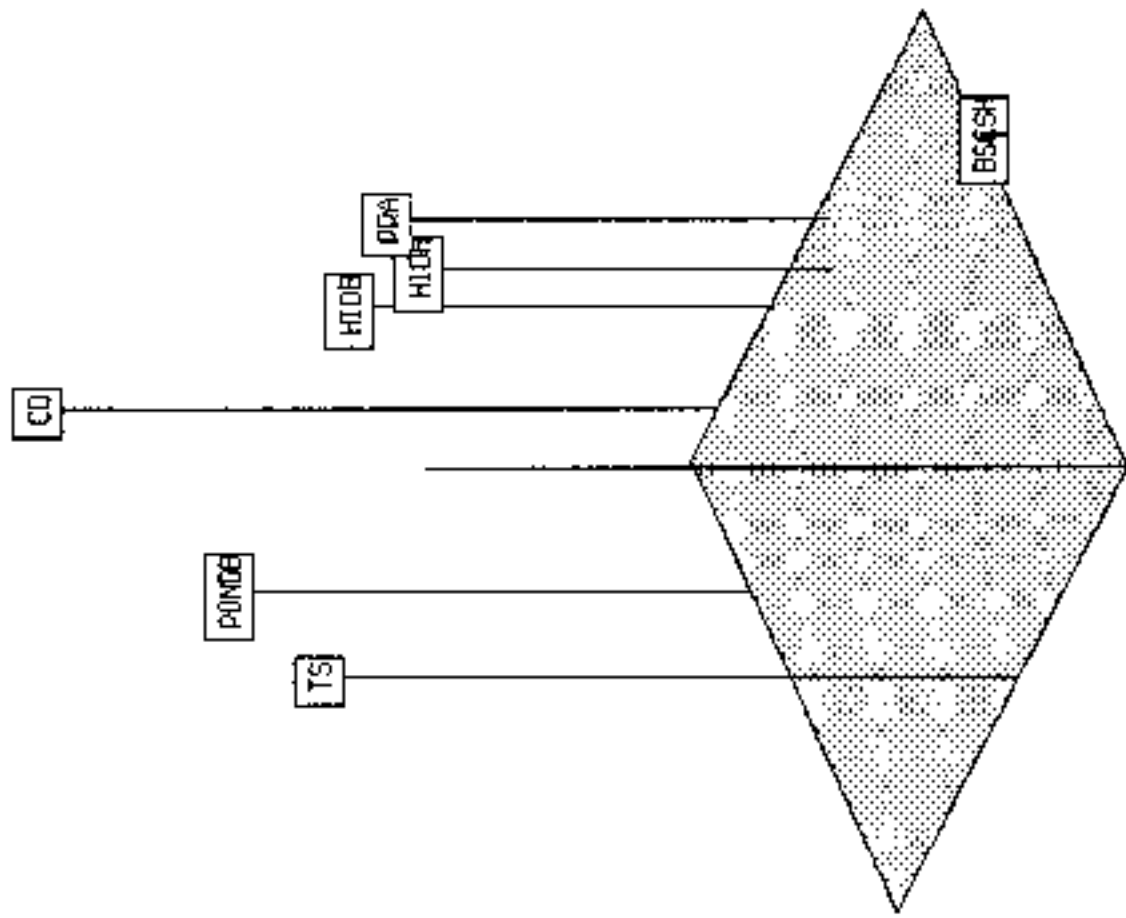

Figure 6. Principal components analysis (PCA) of standardized fish data by habitats (data and codes are from Table 1).

# Standardized Fish data



a= 43 b= 29 r=99.0

Figure 7. Principal components analysis (PCA) of standardized fish data by taxa (data and codes from Table 1).

# Standardized Fish data

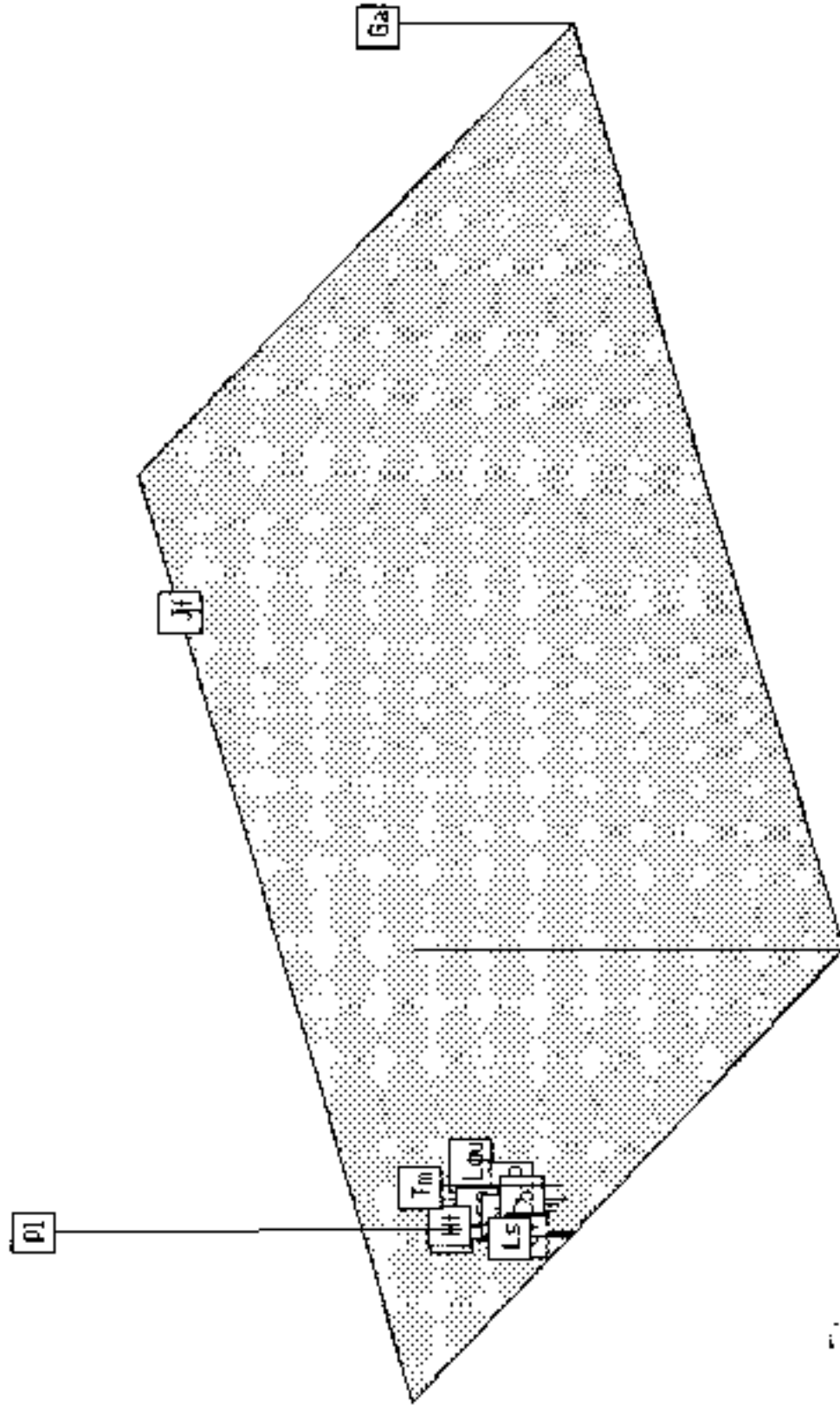

a= 29 b= 32 r=99.0

Figure 8A. Relative abundance (percent occurrence in samples) of tadpole species in habitats (codes from Table 2).

# A. TADPOLE SPECIES COMPOSITION

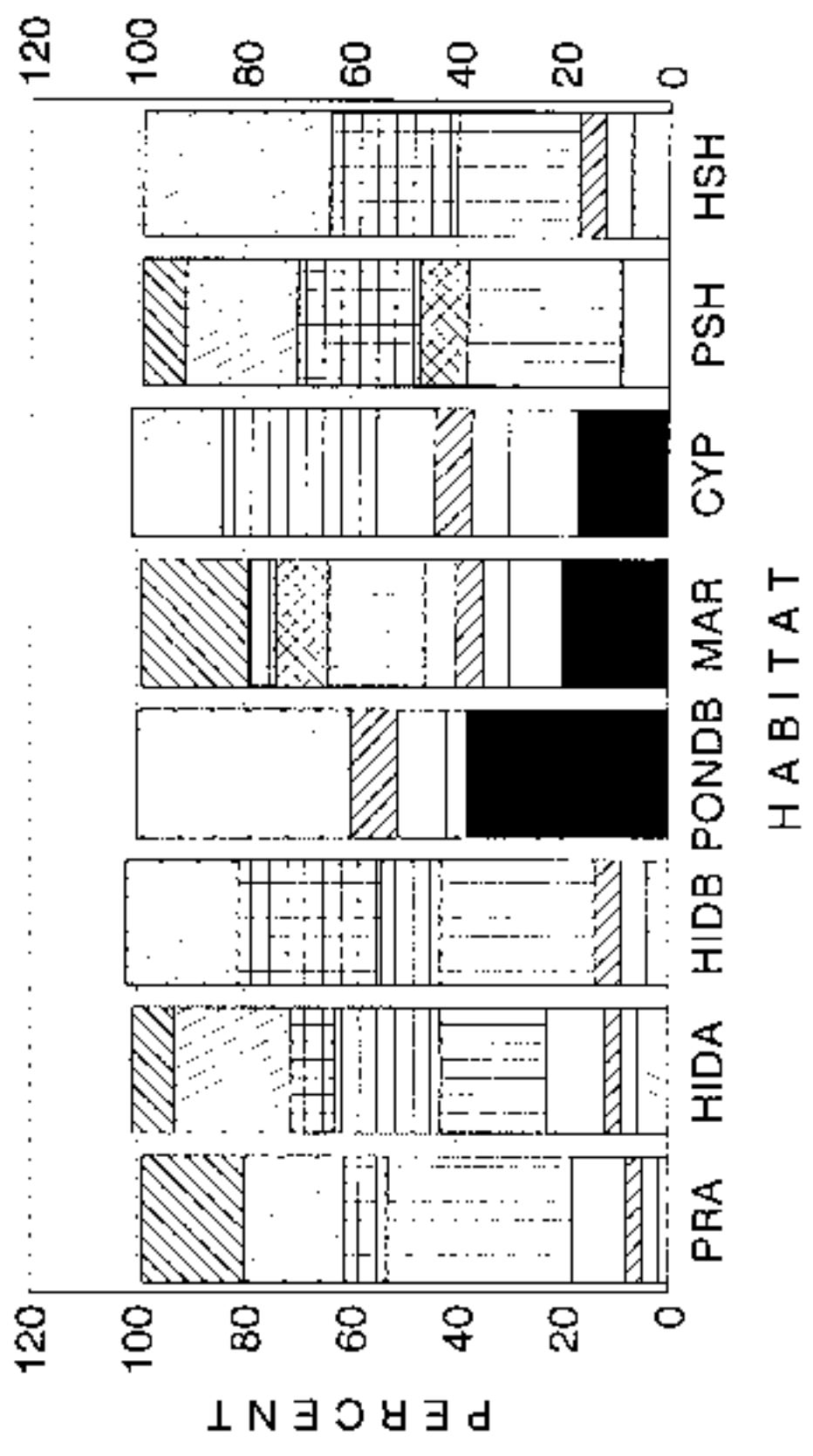

Species codes

- RG
- RS
- HC
- ▨ HS
- ▩ PN
- OS
- LO
- ▨ AG
- ▨ GC
- BT
- ▨ BQ

Figure 8B. The duration of larval period for tadpoles (codes from Table 2).

## B. DURATION OF LARVAL PERIOD

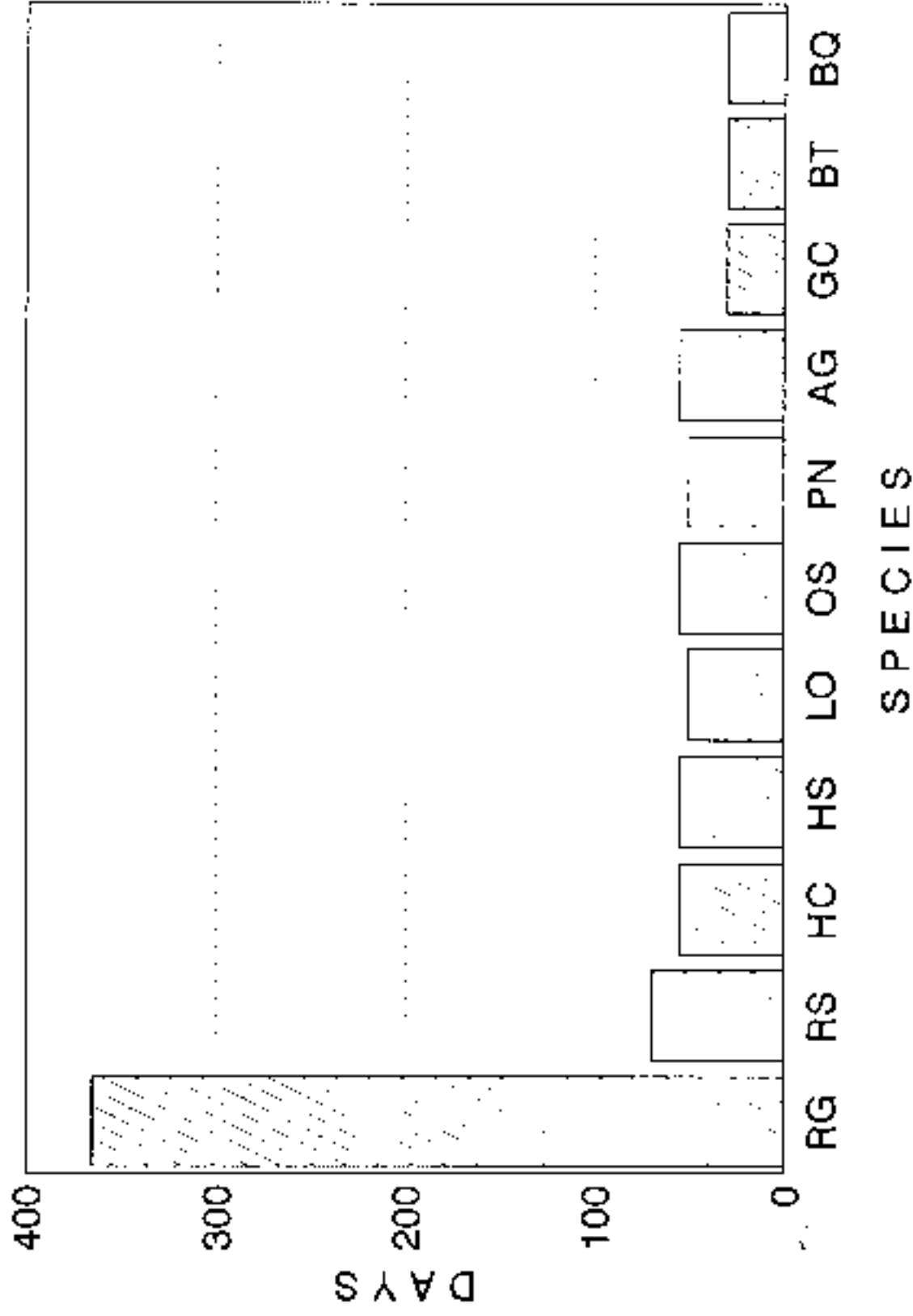

Figure 9. Cluster analysis of tadpole data based on absence/presence in Table 2, codes from Table 2).

# Tad. Qual, SM, UPGMA

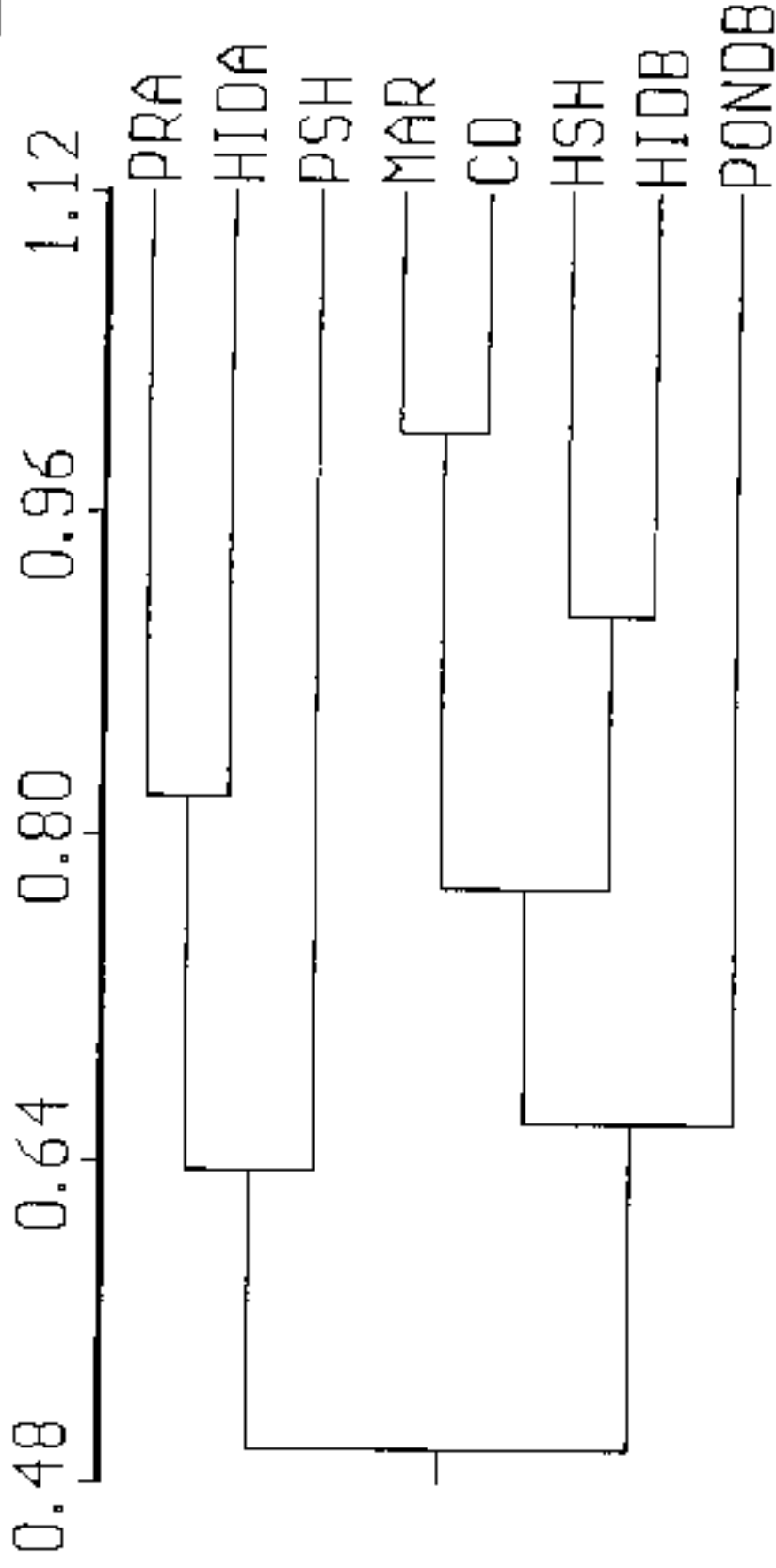

Figure 10. Cluster analysis of tadpole data from Figure 3 and Table 1

# Tadpole cluster - Qualitative

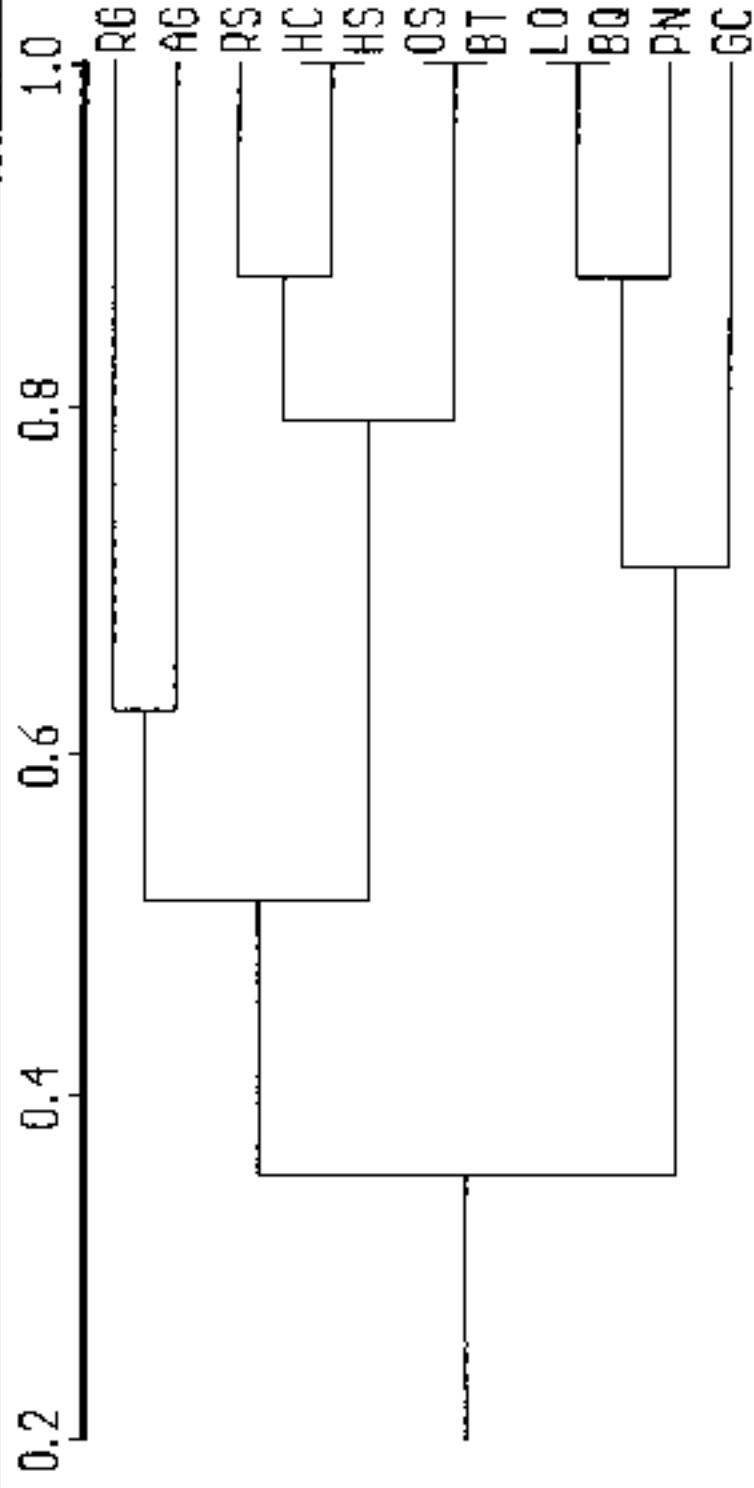
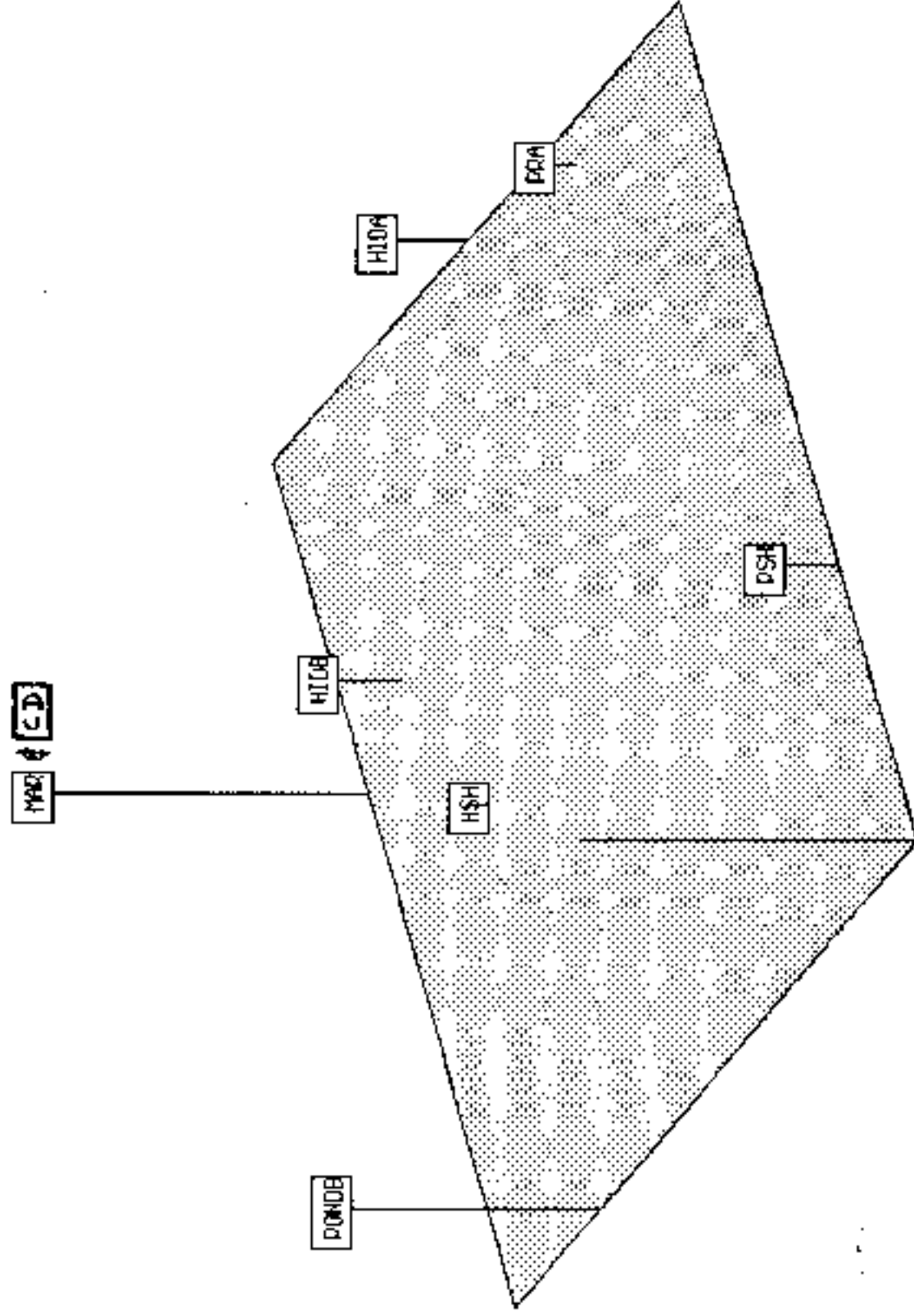

Figure 11. Principal components analysis (PCA) of tadpole data by habitats, based on absence/presence in Table 2, codes from Table 2; Cypress Dome, CD, data is identical loading on all three principal components as Marsh, MAR, data).

# Tadpole data - 0/1 matrix



a= 30 b= 30 r=99.0

Figure 12. Cluster analysis of drift fence samples by habitat using standardized data based on Table 3 (codes for taxa and habitats in Table 3; data for Prairies and Brazilian pepper forest in HID (= DIST) are from Dalrymple, 1988).

# Drift-fence herptile data

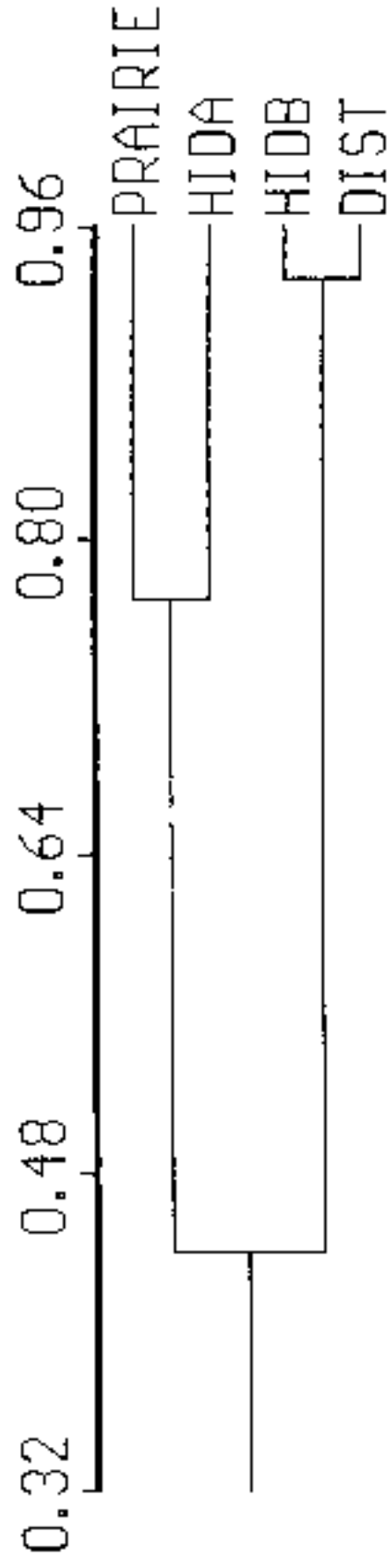

Figure 13. Cluster analysis of drift fence samples by species using standardized data based on Table 3 (codes for taxa and habitats in Table 3; data for Prairies and Brazilian pepper forest in HID (= DIST) are from Dalrymple, 1988).

# Drifet fence herptile data

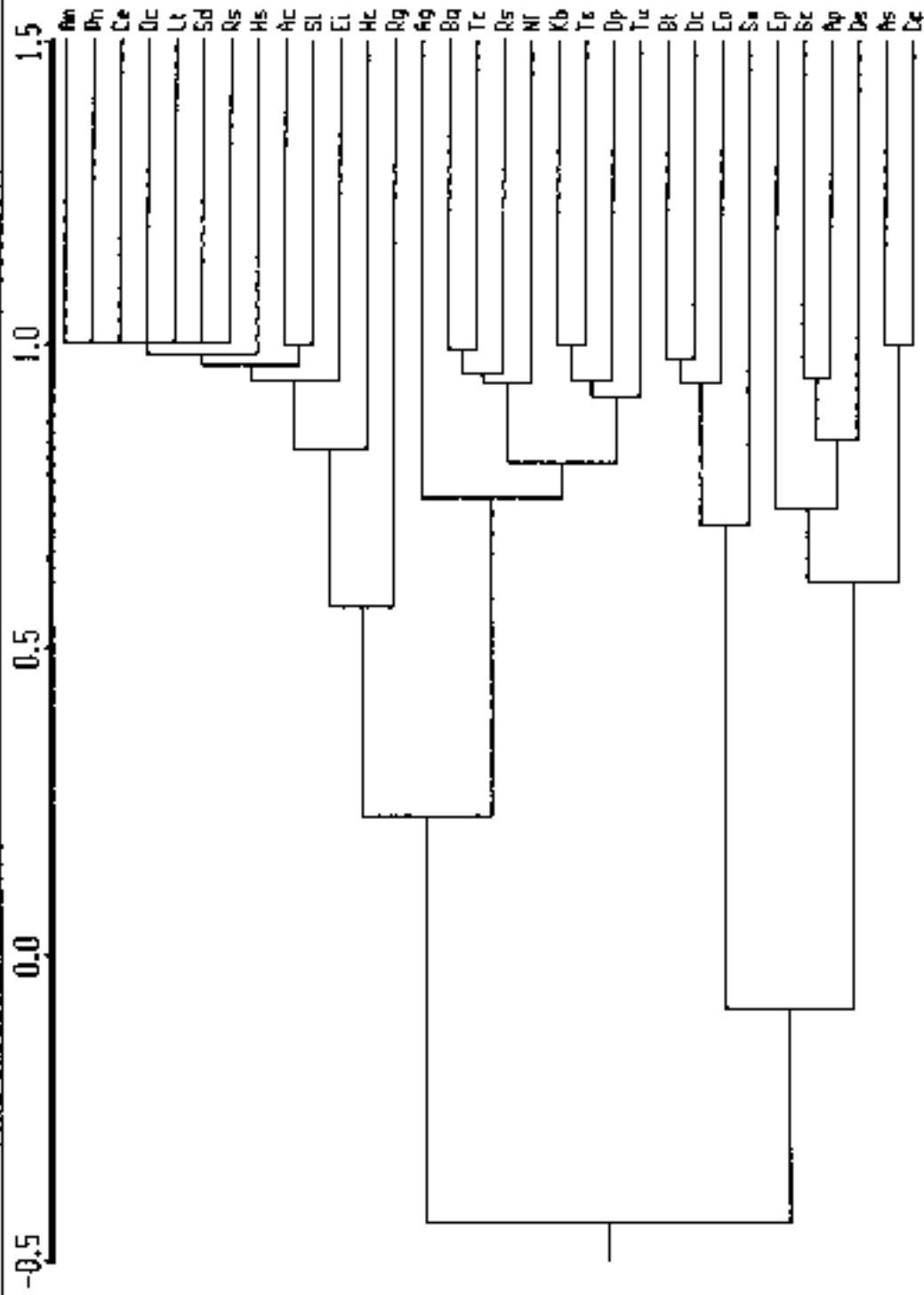
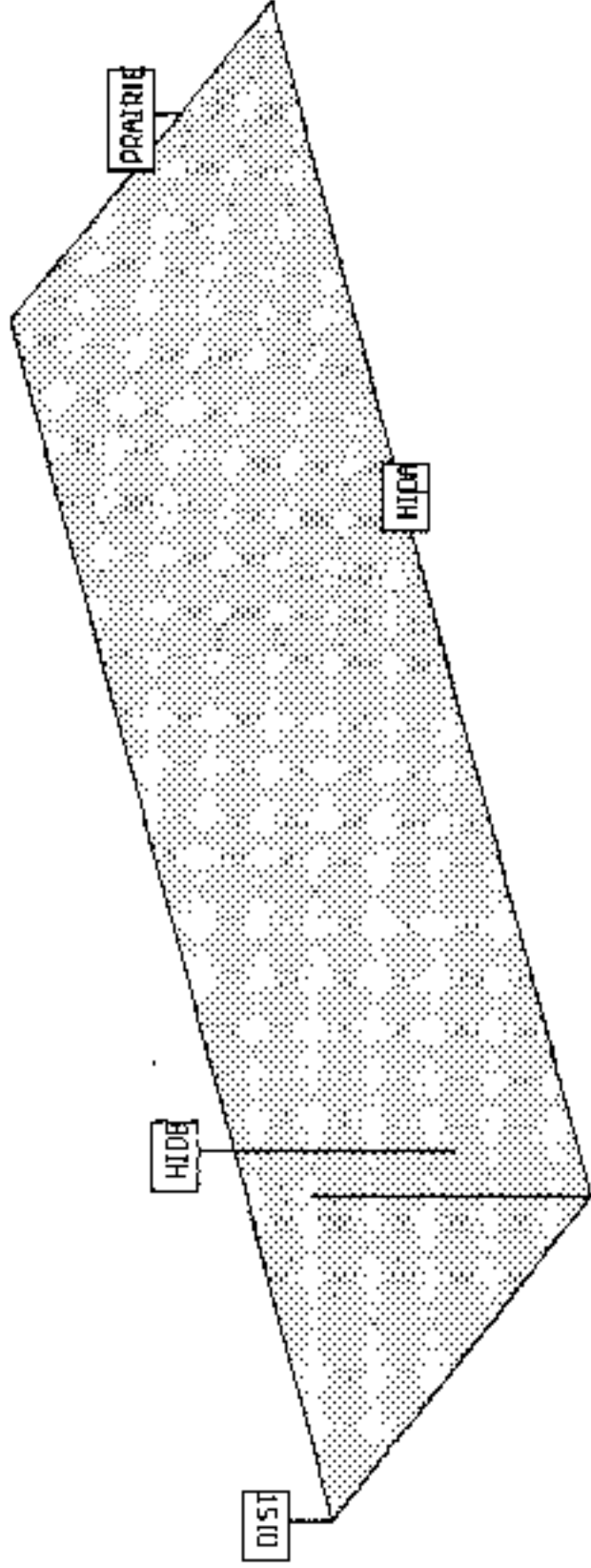

Figure 14. Principal components analysis (PCA) of drift fence samples by habitats using standardized data based on Table 3 (codes for taxa and habitats in Table 3; data for Prairies and Brazilian pepper forest in HID (= DIST) are from Dalrymple, 1988).

# Standardized Drift Fence Data



a= 30 b= 28 r=99.0

Figure 15. Principal components analysis (PCA) of drift fence samples by taxa using standardized data based on Table 3 (codes for taxa and habitats in Table 3; data for Prairies and Brazilian pepper forest in HID (= DIST) are from Dalrymple, 1988).

# Standardized Drift Fence data

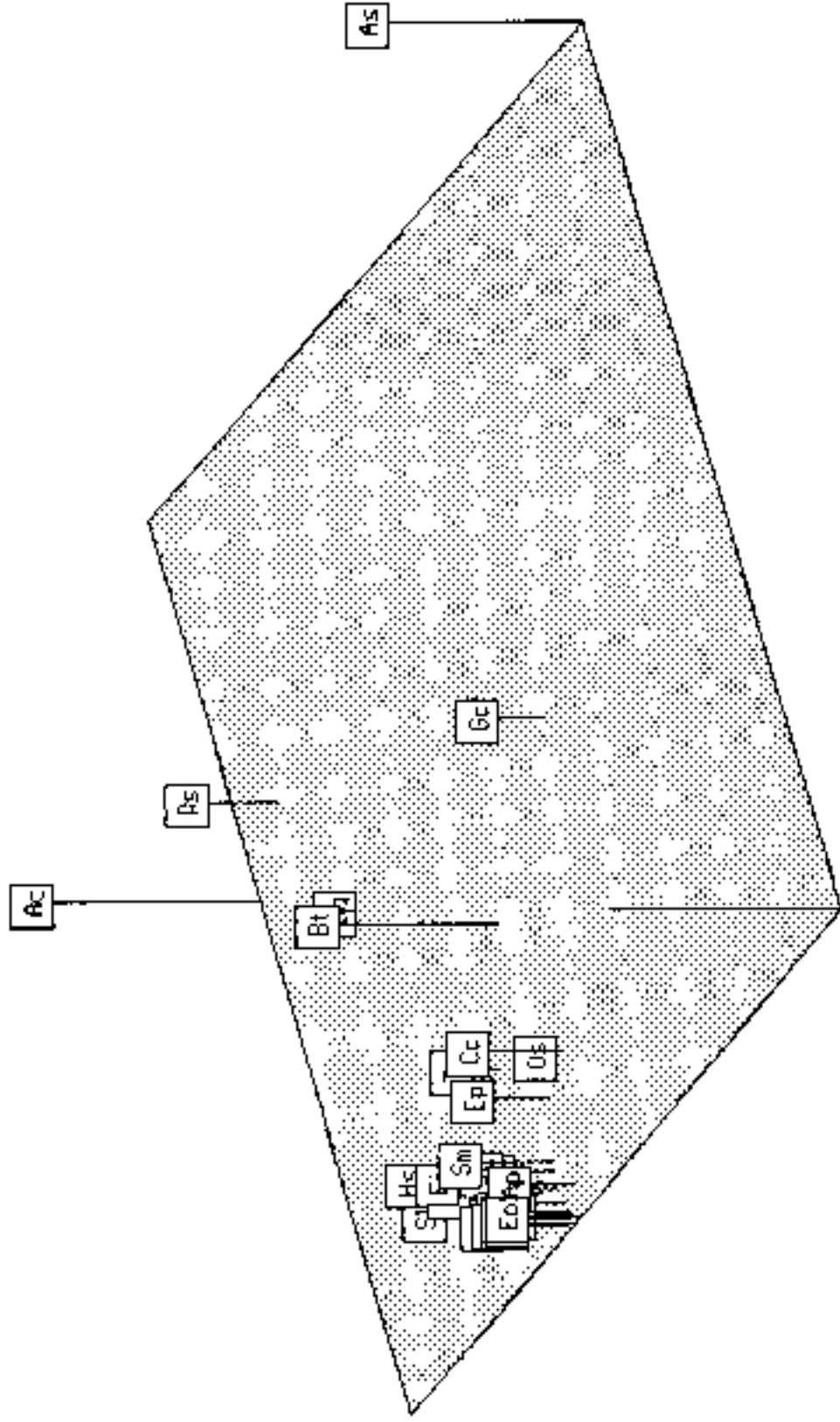

a= 30 b= 30 r=99.0

Figure 16. Percent composition of samples of dragonfly larvae from sampled habitats (codes are from Table 5).

# DRAGONFLY LARVAE

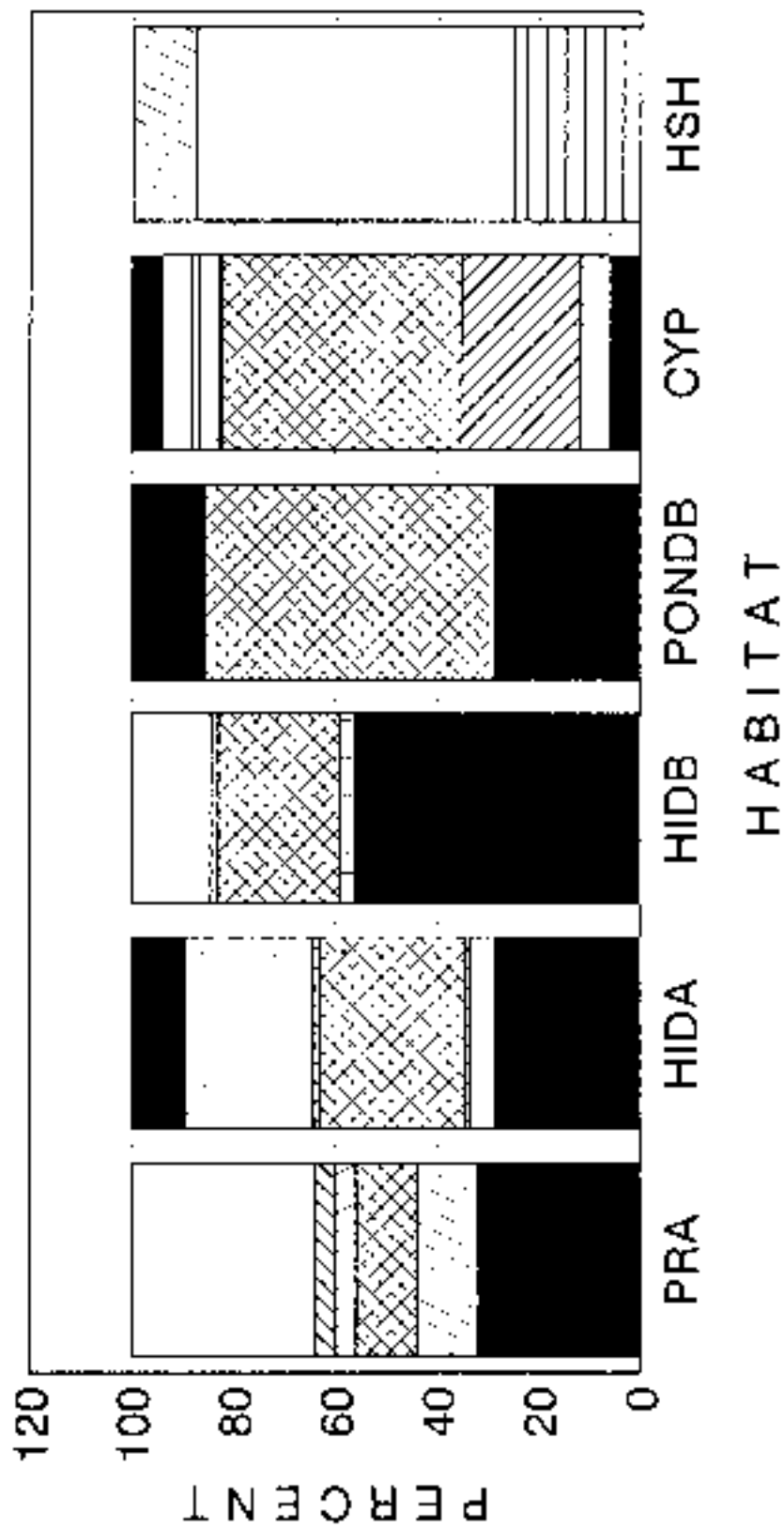

## Species codes

- An
- Of
- Pa
- Ce
- Co
- Ld
- Li
- Np
- Pe
- Pl
- Tr
- Tt

Figure 17. Cluster analysis of standardized dragonfly larval data by habitats (code and data from Table 5).

# Dragonfly data

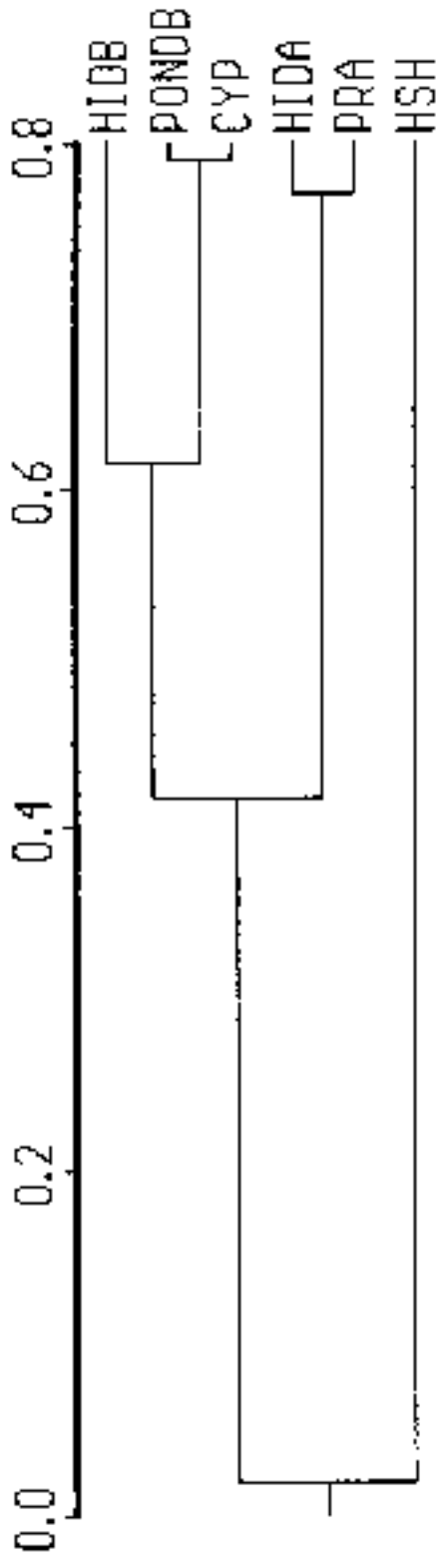

Figure 18. Cluster analysis of standardized dragonfly data by taxa (codes and data from Table 5).

# Dragonfly data

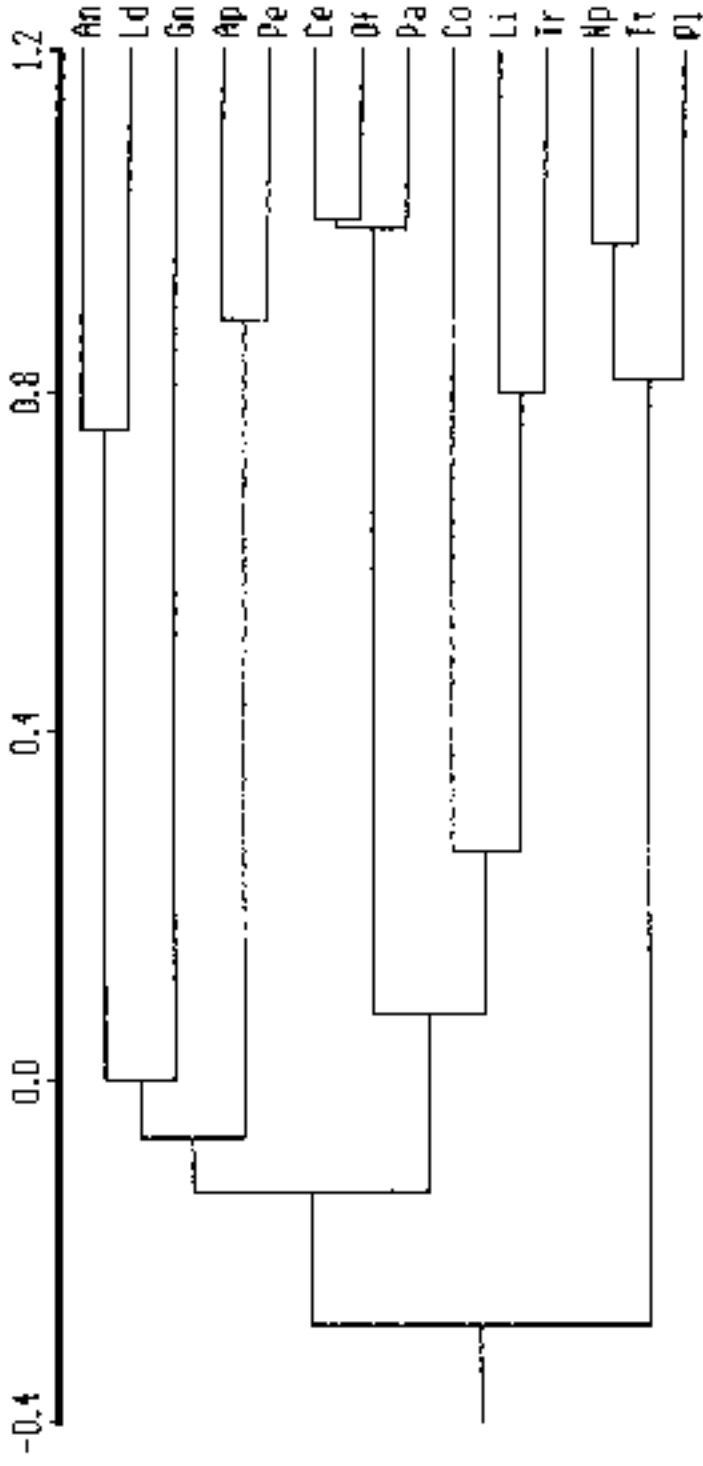
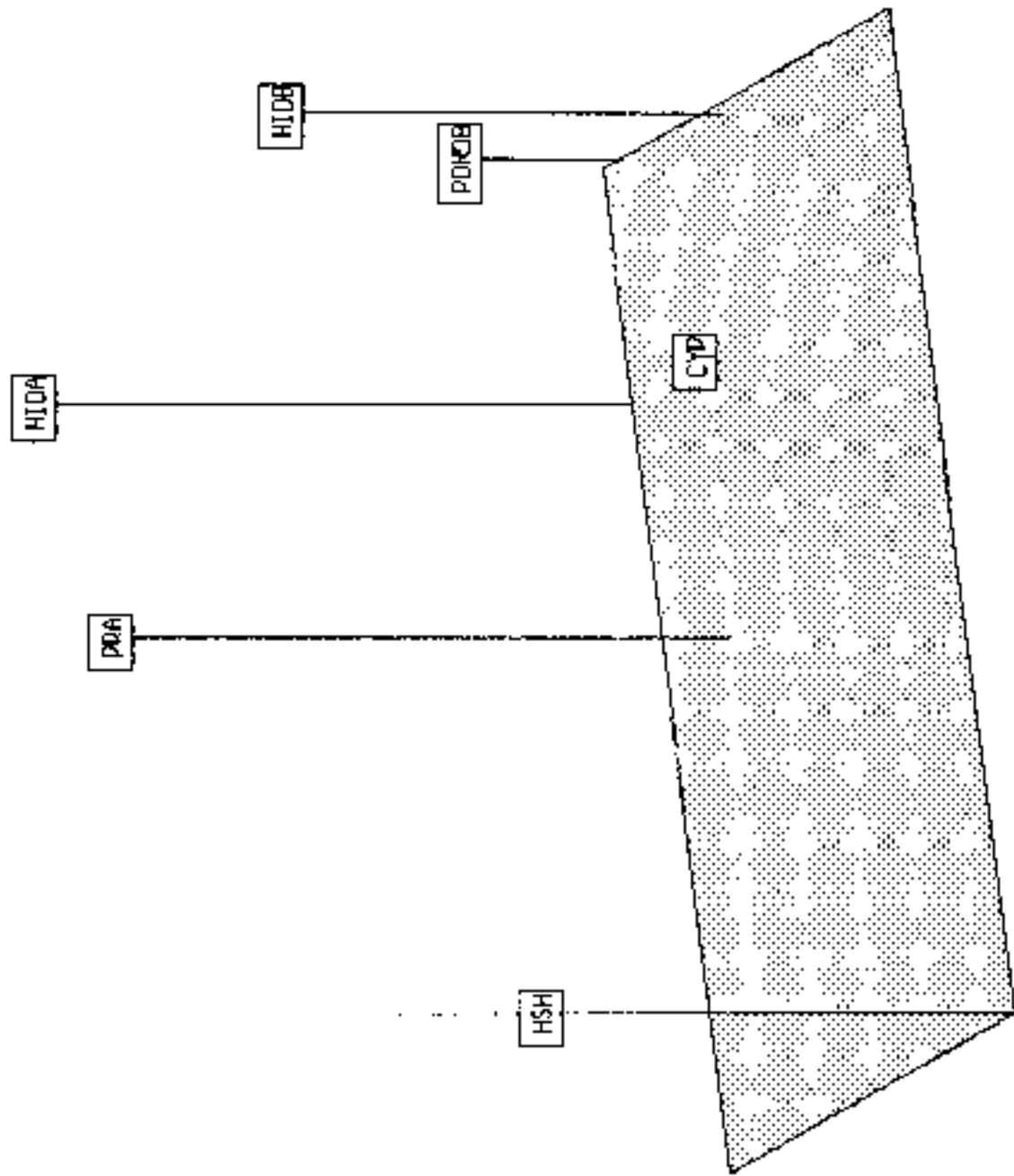

Figure 19. Principal components analysis (PCA) of standardized dragonfly larval data by habitats (codes for taxa and habitats from Table 5).

# Dragonfly data



a= 15 b= 28 r=99.0

Figure 20. Principal components analysis (PCA) of standardized dragonfly larval data by taxa (codes for taxa and habitats from Table 5).

# Dragonfly larvae

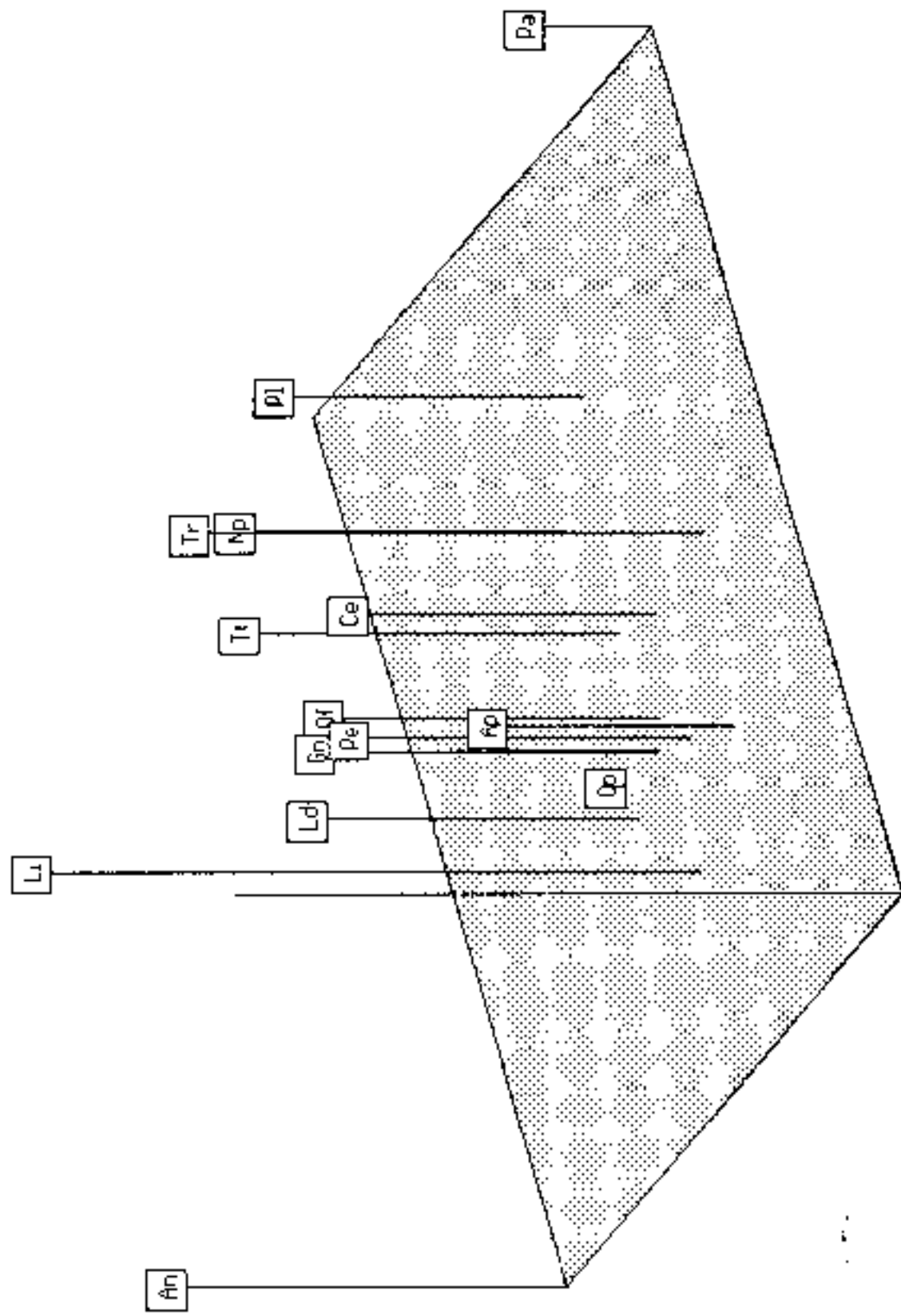

a= 30 b= 30 r=99.0

APPENDIX 1.

Locations sampled by habitat type.

Prairies: #s 1,2 & 3 along the north side of the road to the Dan Beard Center (Research Rd.) at distances of 1.5, 2.6, and 3.1 miles west of the stop sign at the east end of the road.

#4: on north side of the Main Park Rd, 0.4 miles west of turn off to Royal palm Visitor Center.

Cypress Domes: Four domes in the Pa-hay-okee area of the park along the Main Park Rd. and the road to the Pa-hay-okee overlook.

Hammock Solution Holes: In Palma Vista 1; Redd Hammock; Royal Palm Hammock; Osteen Hammock; and Wright Hammock.

Pineland Solution Holes. In the Boy Scout Camp; next to Redd Hammock, in the area adjacent to the Long Pine Key Campground; two additional sites along the unpaved fire road on the west side of Long Pine Key in Pine Block B.

Willow heads: four willow heads in four finger glades in Long Pine Key.

Comments on habitat types.

Prairie - dominated by short sawgrass and muhly grass.

Periphyton is dominant in much of area, but varies greatly in extent. Marl soils and rocky irregular limestone surface, with numerous small solution holes. Larger solution holes may be gator holes, usually distinguishable as willow heads. Some larger ones with open canopy areas with extensive submerged rooted vegetation, e.g. Proserpinaca and Bacopa.

Marsh - dominated by tall sawgrass, alligator flag, pickerel weed, rushes, and cattails. Some with areas of extensive submerged rooted vegetation, e.g. Proserpinaca and Bacopa.

Periphyton is dominant in much of the area. Peat soils and large solution holes, commonly gator holes, usually distinguishable as willow heads. Taylor Slough was regularly used for marsh comparisons.

Pineland Solution Hole - dominated by open canopy of slash pine and a diverse understory, with immediate area of slotting holes with sawgrass, and willow. Periphyton not typical. Substrates are organic and variable amounts of pine needle leaf litter is common. Some larger ones with areas of extensive submerged rooted vegetation, e.g. Proserpinaca and Bacopa. Most dry out every year.

Hammock Solution Hole - dominated by heavy forest canopy with little or no vegetation around the hole. Willow common in larger ones. Periphyton not typical. Substrates are organic

and deep layers of broad leafed leaf litter is common and peat are common. Most dry out under current hydrological regimes, but many stayed wet longer before mid-century.

Cypress Dome - dominated by variable canopy of cypress; hardwoods including pond apple, willow and ficus serve as secondary invaders. Deep deposits of leaf litter and peat are common. Much of open canopy areas with extensive submerged rooted vegetation, e.g. Proserpinaca and Bacopa. Periphyton uncommon. Central depressions or holes commonly are gator holes. Many dry out completely under current hydrological conditions.

Restoration Site A (HID A) - A single large area of early secondary successional sedges, grasses, rushes. Much of area with extensive aquatic rooted vegetation, e.g. Proserpinaca and Bacopa. Periphyton and Utricularia are dominant in water, with thick expansive mats by late wet season. Shallow standing water during most of the wet season. Water concentrates in a few large ponds or holes in dry season. Goes dry in most years. Soils that are developing are marl. Limestone exposed throughout but not as irregular a surface as for Prairies (above).

Restoration Site B - HIDB- Only parts of this area are seasonally submerged. Duration of flooding is shorter than in HIDA. Dominant vegetation is shrub sized hardwoods and herbaceous species in very high density and coverage.

Brazilian pepper continues to increase in coverage. Parts of the area where the shrub layer is not too thick have mats of submerged rooted vegetation. Periphyton is not abundant. Soils are residual farmland and marl. Limestone not exposed at surface.

Restoration Site B pond - Pond B - a unique site, in that it is an artificial pond of 600 square foot surface area, and depths of four feet. It is used as a gator hole. Much of the surface is open water with submerged rooted vegetation dominant, periphyton is not typical. Deepest portions with no vegetation. The substrate is composed of residual farmland. This habitat was sampled separately to determine how distinct its fauna was from the HID B site as a whole (above). It was not an intentional restoration element; its flora and fauna are more typical of a wetland a permanent hammock solution hole, or an artificial pond (e.g. Palma Vista 1 excavated pond on the west side Old Ingraham Highway). Pond B was the only portion of the restoration area that had an alligator, Alligator mississippiensis, in it (one young adult female took up residence in the pond during the first six months after the area was cleared by bulldozers).

Every one of these habitats is characterized by seasonal change in extent and depth of standing water. All habitats eventually have the water level reduced to a few solution holes and or finally completely dry out. In pinelands and hammocks, the solution holes are usually small and very short

lived. A few exceptions include: the Boy Scout Camp pineland solution hole (40 square feet of surface area and a depth of up to three feet) the well known solution hole along Anhinga Trail in Royal Palm Hammock, several large solution holes in Palma Vista 1, and the excavated pond in Palma Vista I hammock.

Appendix 2. Copy of Dalrymple (1988) publication on drift fence trapping of herpetofauna in the Hole-in-the-Donut, and Prairies of Long Pine Key (see Table 3, p 78).